

**Two Rack Unit (2RU)  
Fiber Management Tray (FMT)**

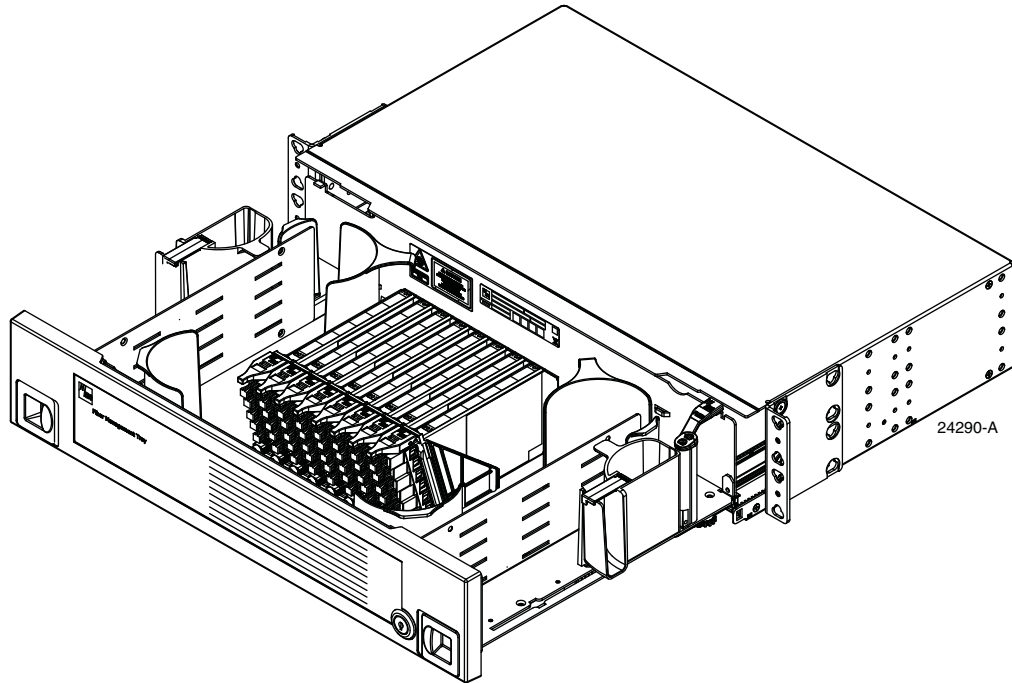

2RU FMT (Micro-VAM Configuration Shown)

Content	Page
INTRODUCTION .....	2
1 PRODUCT INTRODUCTION .....	3
1.1 General Description .....	3
1.2 Configurations and Components .....	4
1.2.1 Termination (Universal Entry) .....	4
1.2.2 Termination (Left Entry for IFC) .....	6
1.2.3 Micro-VAM .....	6
1.2.4 48-Position Termination/Splice .....	7
1.2.5 Bulk Storage .....	9
1.3 Attenuators .....	9
2 DIMENSIONS AND SPECIFICATIONS .....	9
3 UNPACKING THE PRODUCT .....	11
4 MOUNTING THE 2RU FMT ON THE RACK .....	12
5 INSTALLING MICRO-VAMS .....	12

(continued)

Content	Page
<b>6 INSTALLING AND ROUTING CABLES</b> .....	<b>14</b>
6.1 General Cable Information .....	14
6.2 Internal Cable Routing .....	15
6.2.1 Termination (Universal Entry) .....	15
6.2.2 Termination (Left Entry for IFC) .....	17
6.2.3 Micro-VAM .....	19
6.2.4 48-Position Termination/Splice .....	21
6.2.5 Bulk Storage .....	24
<b>7 OPERATION</b> .....	<b>26</b>
7.1 Opening the Tray .....	27
7.2 Sliding Adapter Packs .....	27
7.3 Micro-VAMs .....	28
7.4 Closing the Tray .....	29
<b>8 TECHNICAL ASSISTANCE</b> .....	<b>30</b>

## INTRODUCTION

This manual describes the Two-Rack Unit (2RU) Fiber Management Tray (FMT) and provides all information required to install and use this product.

## Revision History

ISSUE	DATE	REASON FOR CHANGE
1	3/2011	Original

## Trademark Information

CommScope (logo), CommScope, and ADC are trademarks, Scotchlok are registered trademarks of 3M Company. FiberLok is a trademark of 3M Company. VELCRO is a registered trademark of Velcro Industries, B.V.

## Admonishments

Important safety admonishments are used throughout this manual to warn of possible hazards to persons or equipment. An admonishment identifies a possible hazard and then explains what may happen if the hazard is not avoided. The admonishments — in the form of Dangers, Warnings, and Cautions — must be followed at all times. These warnings are flagged by use of the triangular alert icon (seen below), and are listed in descending order of severity of injury or damage and likelihood of occurrence.





**Danger:** *Danger is used to indicate the presence of a hazard that will cause severe personal injury, death, or substantial property damage if the hazard is not avoided.*

 **Warning:** Warning is used to indicate the presence of a hazard that can cause severe personal injury, death, or substantial property damage if the hazard is not avoided.

 **Caution:** Caution is used to indicate the presence of a hazard that will or can cause minor personal injury or property damage if the hazard is not avoided.

## General Safety Precautions

 **Caution:** Fiber optic cables may be damaged if bent or curved to a radius that is less than the recommended minimum bend radius. Always observe the recommended bend radius limit when installing fiber optic cables and patch cords.

 **Danger:** Exposure to laser radiation can seriously damage the retina of the eye. Do not look into the ends of any optical fiber. Do not assume the laser power is turned-off or that the fiber is disconnected at the other end.

 **Caution:** Improper handling can damage fiber optic cables. Do not bend fiber optic cable more sharply than the minimum recommended bend radius specified by the cable manufacturer. Do not apply more pulling force to the cable than specified. Do not compress the fiber or allow it to kink.

 **Caution:** Placing a load in excess of 12 pounds (5.4 kg) onto an open tray will result in misalignment or damage to the tray.

## 1 PRODUCT INTRODUCTION

This section introduces the Two-Rack Unit (2RU) Fiber Management Tray (FMT).

### 1.1 General Description

The Two-Rack Unit (2RU) Fiber Management Tray (FMT) is a rack-mount fiber optic panel consisting of a basic chassis with a slide-out drawer and a drop-in plate (DIP) installed inside the drawer to provide various functions such as cable termination. The basic chassis is the same for all models of the 2RU FMT. The drop-in plate, which is installed in the factory, depends on customer order. [Figure 1](#) shows a 2RU FMT with a drop-in plate providing a micro-VAM splitter function.

The 2RU FMT is available with the following rack-mount options:

- EIA or WECO, 19-inch (48.26 cm);
- EIA or WECO, 23-inch (58.42 cm);
- ETSI, 20.28 inch (51.51 cm);
- All rack-mount options (EIA, WECO, or ETSI) provide the following recess options: 2.2-inch (5.59 cm), 5-inch (12.70 cm), 6-inch (15.24 cm), or 40 mm (1.6 inch).

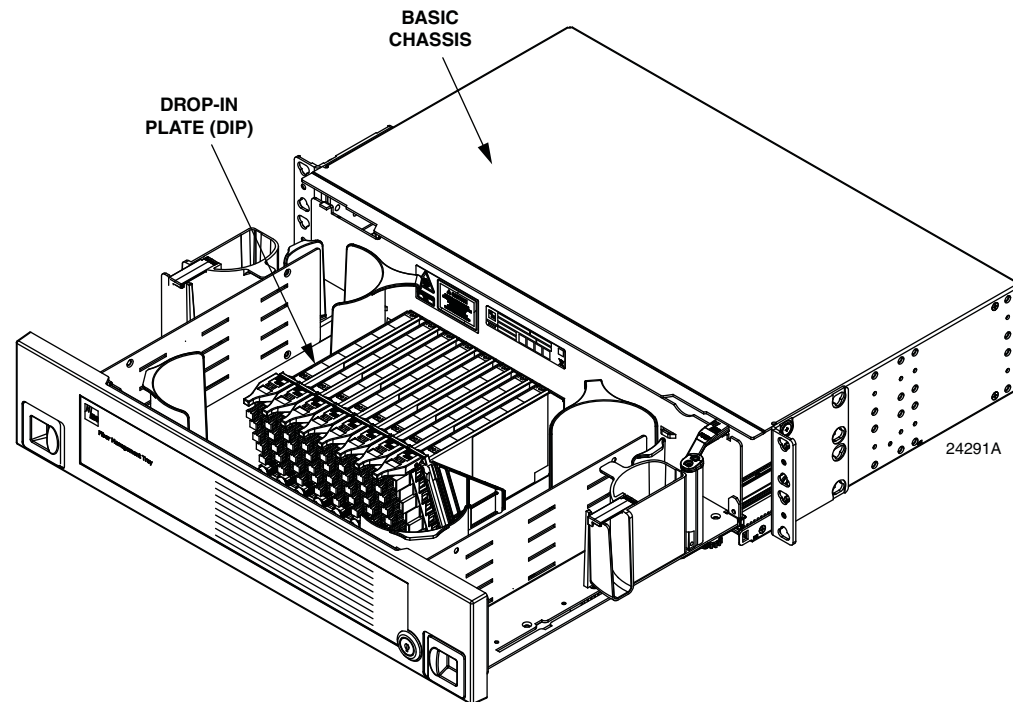

Figure 1. 2RU FMT (Micro-VAM Model Shown)

## 1.2 Configurations and Components

The 2RU FMT is currently available in a variety of DIP configurations, with more being developed based on customer requests. The configurations available as of this printing of this manual are:

- Termination (FMT-GRT, universal entry);
- Termination (FMT-GN7, left entry for Intrafacility Fiber Cable);
- Micro-VAMs (FMT-GVM, universal entry);
- 48-position termination/splice (FMT-GTL, left side splice, right side termination).
- Bulk storage (FMT-GBS, universal entry).

For multifiber cable assemblies, FMTs with termination for IFC (left entry) is your best choice. If you are installing patch cords terminated with adapters, universal entry is your best choice.

### 1.2.1 Termination (Universal Entry)

[Figure 2](#) shows the main external features of the 64-position termination model (available with up to 72-terminations).

The features shown include the following (going from bottom left clockwise):

- **Slide Latches (2)**—Hold tray closed. Sliding latches inward releases tray to be opened.

- **Radius Limiters (4)**—Maintain a protective, minimum-bend radius for cables routed into tray. There are two front and two rear radius limiters, as shown.
- **Sliding Adapter 6-Packs (8)**—Provide easy access for connecting cables and cleaning connectors and adapters. A variety of singlemode and multimode connector types are available from ADC. For details, refer to the product catalog.
- **VELCRO Loop Tie-Down Points (Each Side)**—Are used to secure cables to the side of the tray using the velcro loops provided with the product.
- **Wax Lacing Tie-Down Points (Each Side)**—Are used to secure cables on the back of the tray using wax lacing (not provided).
- **Mounting Brackets (2)**—Are used to fasten the tray to the rack.
- **Sliding Radius Limiters (2)**—Provide protected entry points for cables. The movement of these radius limiters is controlled for optimum slack management.
- **Keylock (Optional)**—Provides a means to lock the tray when closed.

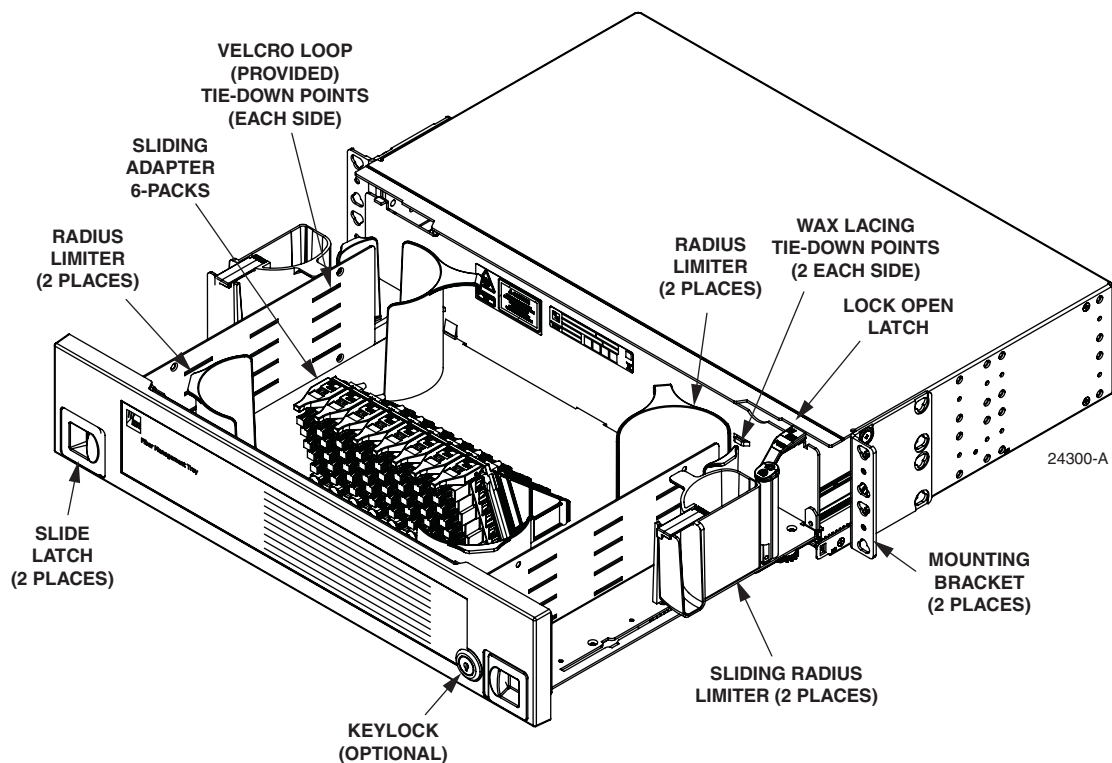

Figure 2. 64-Position Termination Only (Universal Entry) 2RU FMT

### 1.2.2 Termination (Left Entry for IFC)

Figure 4 shows the external features of the 72-position left-entry model, intended for use with IFC. Except for the left-side entry, the components are similar to the universal entry model. For a definition of the callouts, refer to subsection 1.2.1.

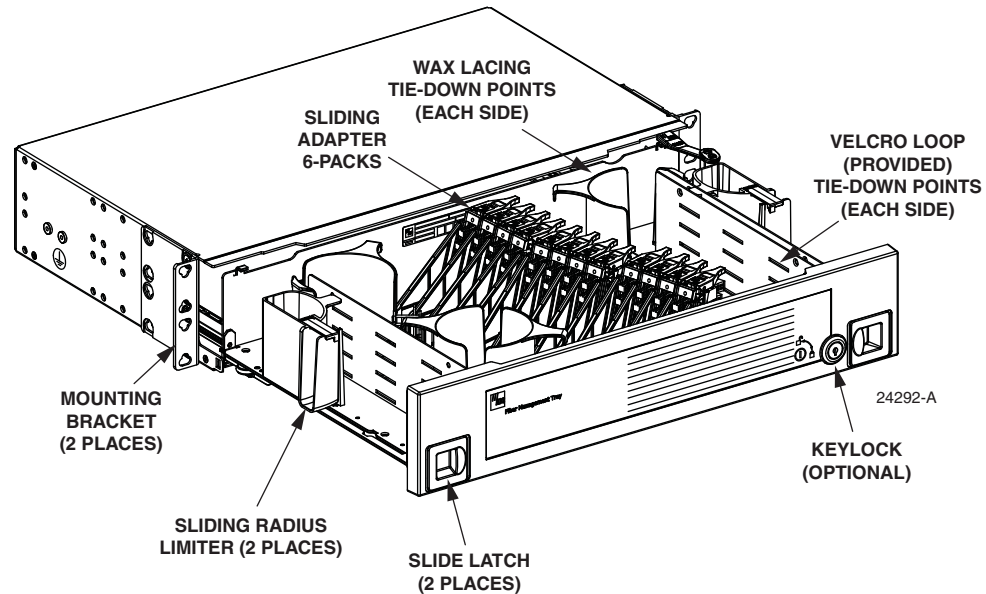

Figure 3. 72-Position Termination (Left Entry for IFC) 2RU FMT

### 1.2.3 Micro-VAM

Figure 4 shows the 64-position micro-VAM model, which has micro-VAMs in place of adapter 6-paks. VAMs (Value Added Modules) are housings for fiber optic splitters and Wave Division Multiplexers (WDM).

Figure 5 shows an example of a dual-circuit micro-VAM with its schematic label.

Micro-VAMs can be either single circuit or dual circuit, and can be populated one at a time.

- Single circuit micro-VAMs have one input port and two output ports.
- Dual circuit micro-VAMs have two input ports and four output ports.

2RU FMT capacity is 12 inputs and 24 outputs for a tray loaded with single-circuit micro-VAMs, and 24 inputs and 48 outputs for a tray loaded with dual circuit micro-VAMs.

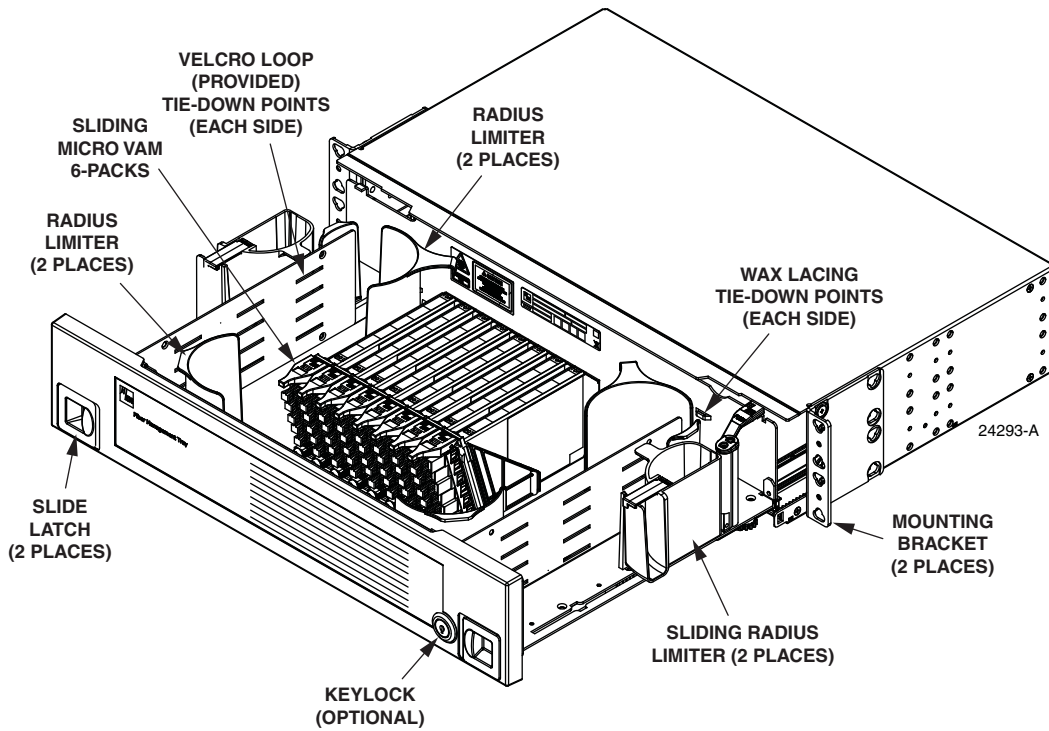

Figure 4. 64-Position Micro-VAM 2RU FMT

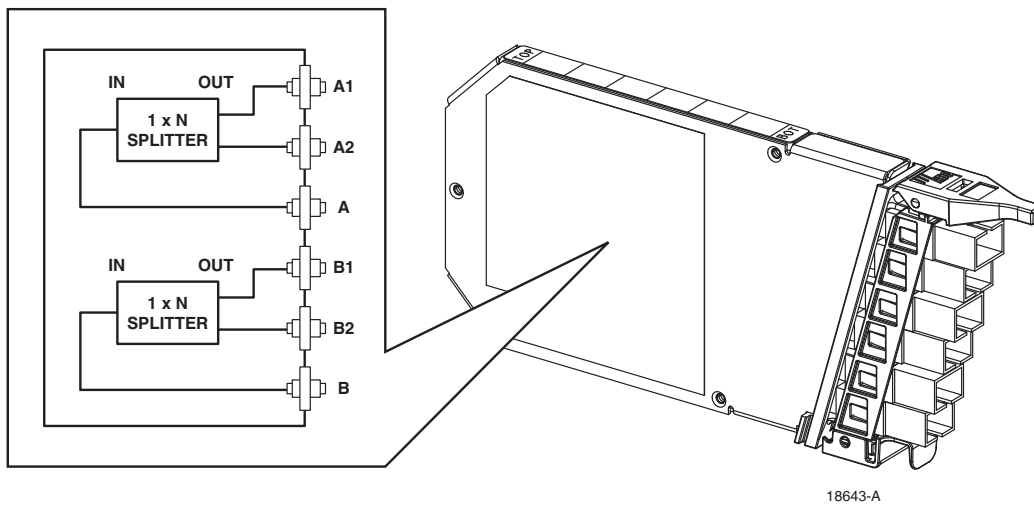

Figure 5. Sliding Micro-VAM With Dual-Circuit Schematic Label

#### 1.2.4 48-Position Termination/Splice

Figure 6 shows the 48-Position Termination/Splice model. This panel has many of the same features as the 72-position termination panel, plus a splice tray. Optical fibers brought into the panel from an outside source are spliced in the splice tray to internal pigtails.

The pigtailed are routed within the drawer to be terminated on the front side of the sliding adapter packs. Optical circuits are completed by connecting connectorized fibers to the rear side of the adapter packs.

This model provides splicing and termination for 48 optical fibers. It holds two splice trays, each with the capacity for 24 splices. It has eight adapter six packs providing 48 connectorized terminations.

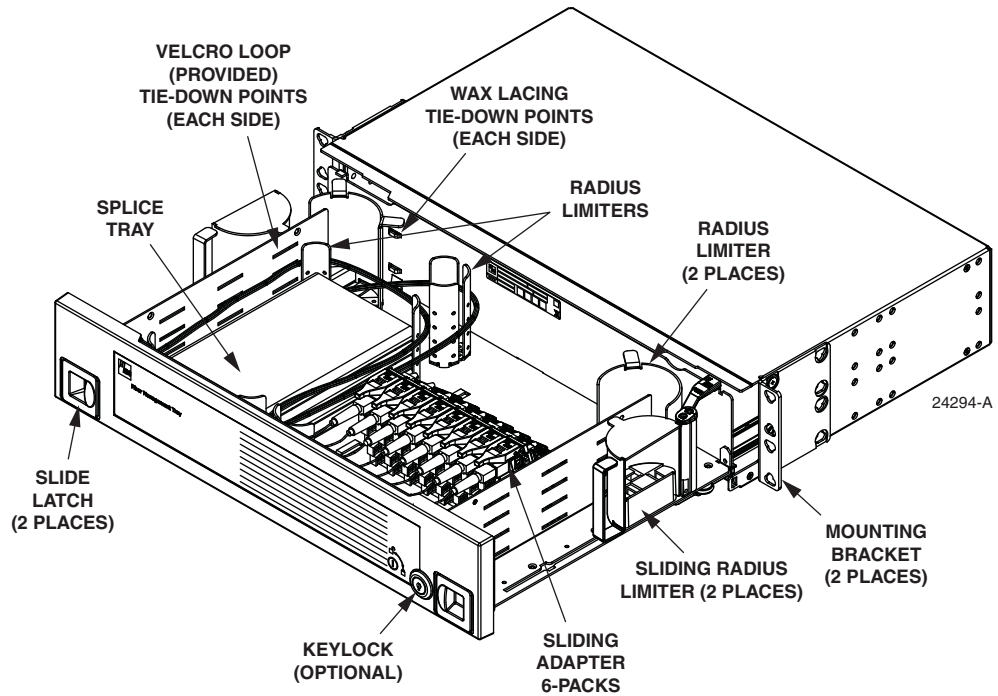

Figure 6. 48-Position Termination/Splice 2RU FMT



### 1.2.5 Bulk Storage

Figure 7 shows the Bulkhead Storage model. This model stores 150 1.6mm patch cords (with two meters stored per patch cord). Patch cords can enter from top or bottom, left or right side.

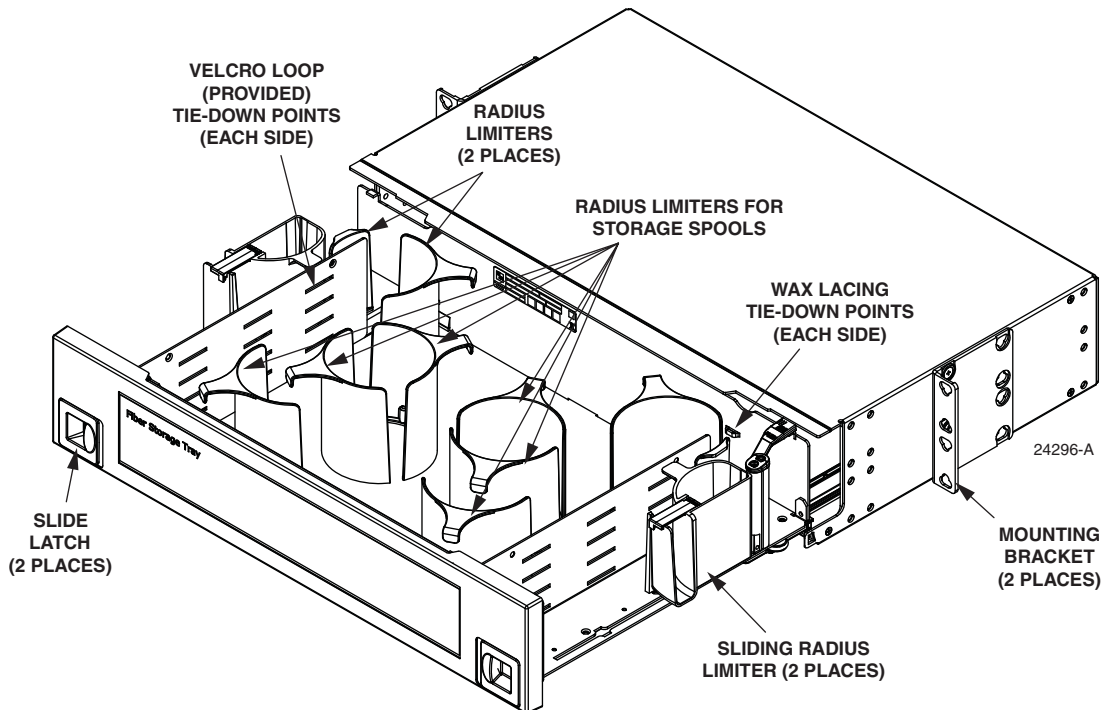

Figure 7. Bulkhead Storage 2RU FMT

### 1.3 Attenuators

Attenuators (optional) decrease the optical power in a fiber by a specific or adjustable amount. Once the desired level of attenuation is determined, fixed attenuators may be inserted in the fiber optic line to deliver a precise output. In the 48-position termination/splice (FMT-GTL) configuration and 72-position termination configuration (FMT-GN7), attenuators may be used on either side of the sliding adapter packs. In the 72-position termination (FMT-GRT) configuration, attenuators may only be used on the rear (back) side of sliding adapter packs.

## 2 DIMENSIONS AND SPECIFICATIONS

Figure 8 shows 2RU FMT dimensions for rack type, rack width, and recess options. Table 1 lists specifications for the 2RU FMT.

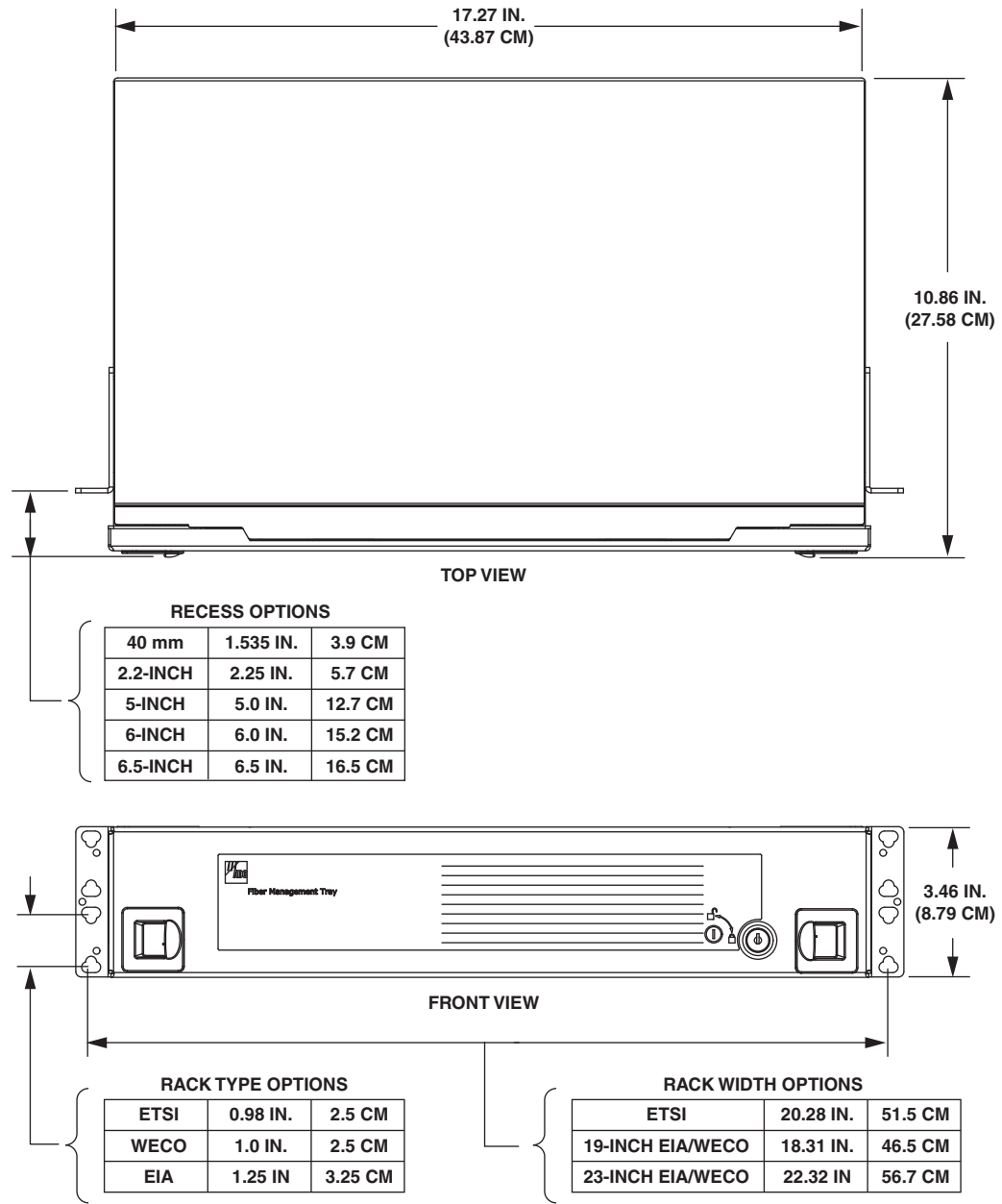

18547-B

Figure 8. 2RU FMT Dimensions

Table 1. 2RU FMT Specifications

ITEM	DESCRIPTION
Dimensions (H × W × D)	See <a href="#">Figure 8</a> . Shipping dimensions 8 x 15.5 x 24 in. (20.3 x 39.4 x 61 cm)
Weight	Approx. 10 lbs. (4.54 Kg) Shipping weight approx. 11 lbs. (5 Kg)
<b>72-POSITION TERMINATION (UNIVERSAL OR LEFT ENTRY)</b>	
Capacity	One tray holds up to 12 adapter 6-packs, providing a capacity of 72 front terminations and 72 rear terminations per tray.
Connector Types	A variety of connector types are available. Refer to the product catalog for a current listing.
<b>72-POSITION MICRO-VAM</b>	
Capacity	With single circuit micro-VAMs: 12 inputs, 24 outputs With dual circuit micro-VAMs: 24 inputs, 48 outputs
Connectors	A variety of connector types are available. Refer to the product catalog for a current listing.
Split Ratio	Split ratios ranging from 98:2 to 50:50 are available. Refer to the product catalog for a current listing.
<b>48-POSITION TERMINATION/SPLICE</b>	
Capacity	48 splices; 48 terminations.
Connectors	Same as above.
Splice tray capacity	Four tray capacity each with two splice chips providing a total of 12 splices.
<b>BULKHEAD STORAGE</b> See <a href="#">Figure 23</a> on <a href="#">page 26</a> .	
Capacity	150 1.6mm patch cords. 115 1.7mm patch cords. 85 2.0mm patch cords. 50 3.0mm patch cords.
Storage per patch cord	2 meters (6.56 feet).

### 3 UNPACKING THE PRODUCT

Unpack and inspect the 2RU FMT as follows:

1. Inspect the exterior of the shipping container for evidence of rough handling that may have damaged the contents of the container.
2. Unpack the 2RU FMT and check for possible damage.
3. If damage is detected or if parts are missing, file a claim with the commercial carrier and then notify ADC Customer Service. Save damaged carton for inspection by the carrier.
4. For repair, replacement, and warranty information, refer to [Section 8](#) on the last page of this manual.
5. Save the shipping container for use if equipment requires shipment at a future date.

## 4 MOUNTING THE 2RU FMT ON THE RACK

For all mounting configurations, the 2RU FMT uses two mounting brackets, one on either side. Each bracket has four mounting holes (see [Figure 9](#)), but only the top and bottom holes are required. Install the tray using the following procedure:

► **Note:** For mounting hole dimensions, see [Figure 8](#).

1. Position the tray on the rack aligning the tray mounting holes with the corresponding holes in the rack.
2. Using the fastening hardware provided, fasten the tray to the rack using four fasteners of the required type. Use the top and bottom holes in each bracket. Leave the two middle holes empty.

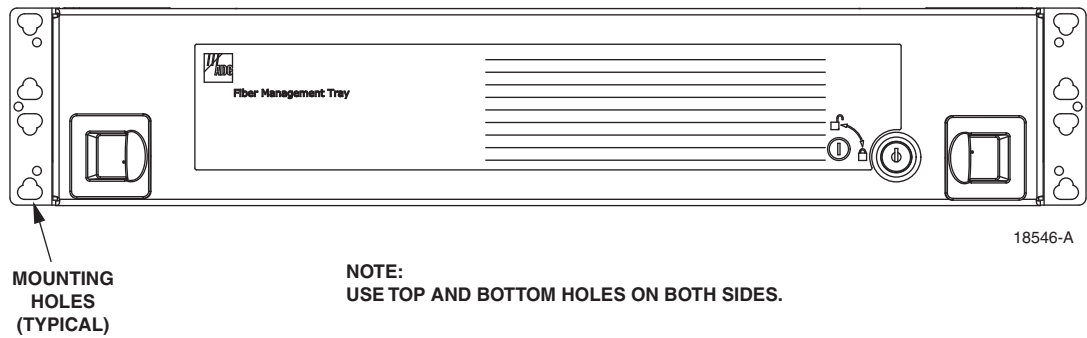

Figure 9. 2RU FMT Mounting Holes

## 5 INSTALLING MICRO-VAMS

Micro-VAM trays are shipped empty. Micro-VAMs if ordered, are packaged separately. To install a micro-VAM, position it as shown in [Figure 10](#) and slide it down into the guide.

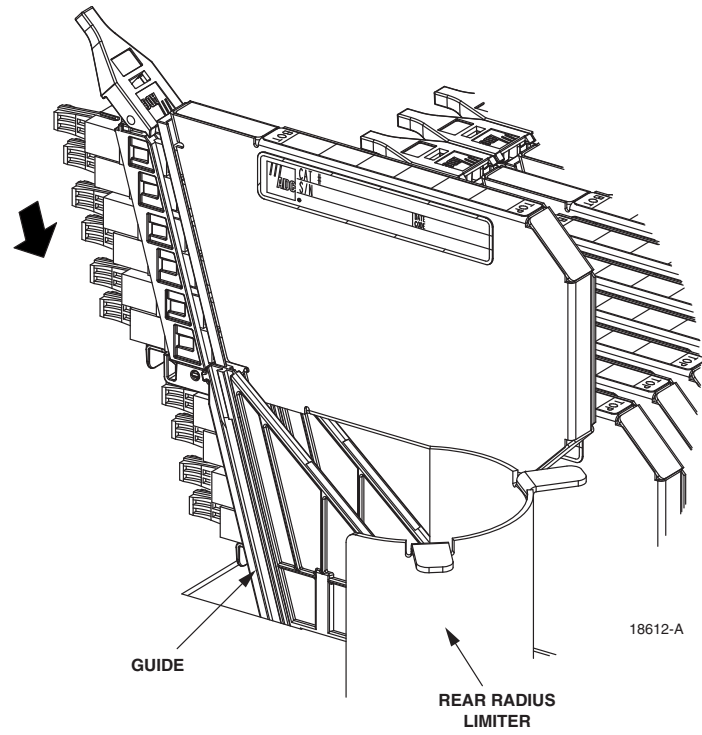

Figure 10. Installing a Micro-VAM

## 6 INSTALLING AND ROUTING CABLES

### 6.1 General Cable Information

Incoming IFC or OSP must be secured with a cable clamp to the frame before entering the FMT, as shown in [Figure 11](#). FMTs may be ordered without IFC or OSP cables installed at the factory. Refer to [Figure 12](#) for appropriate cable length.



**Caution:** Do not route 900 micron fibers through sliding radius limiters. Fiber damage may occur. Route only jacketed fibers through the sliding radius limiters.

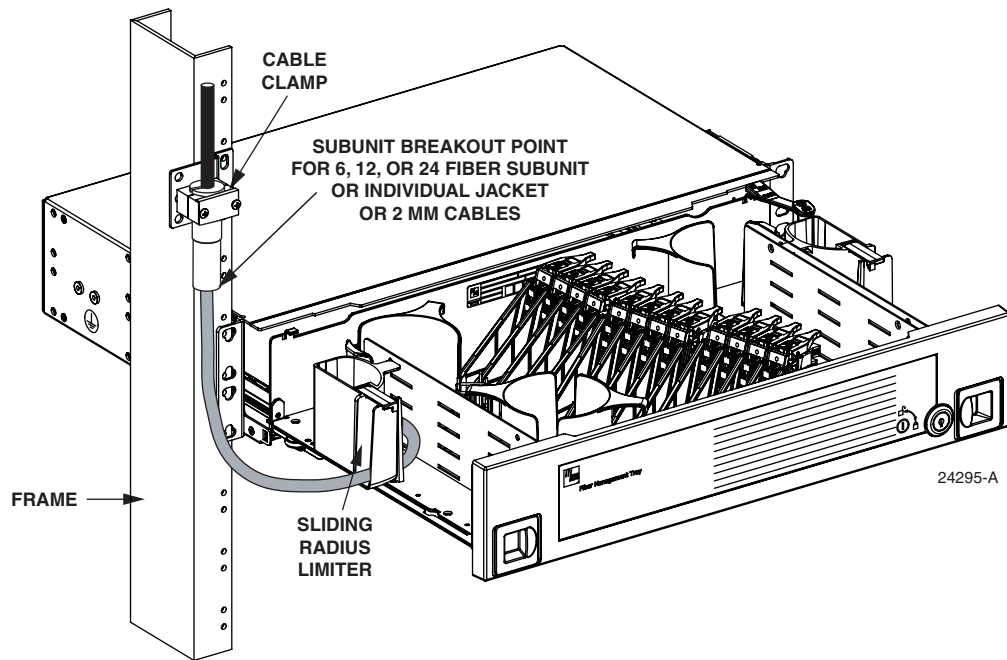

Figure 11. Cable Clamping Point

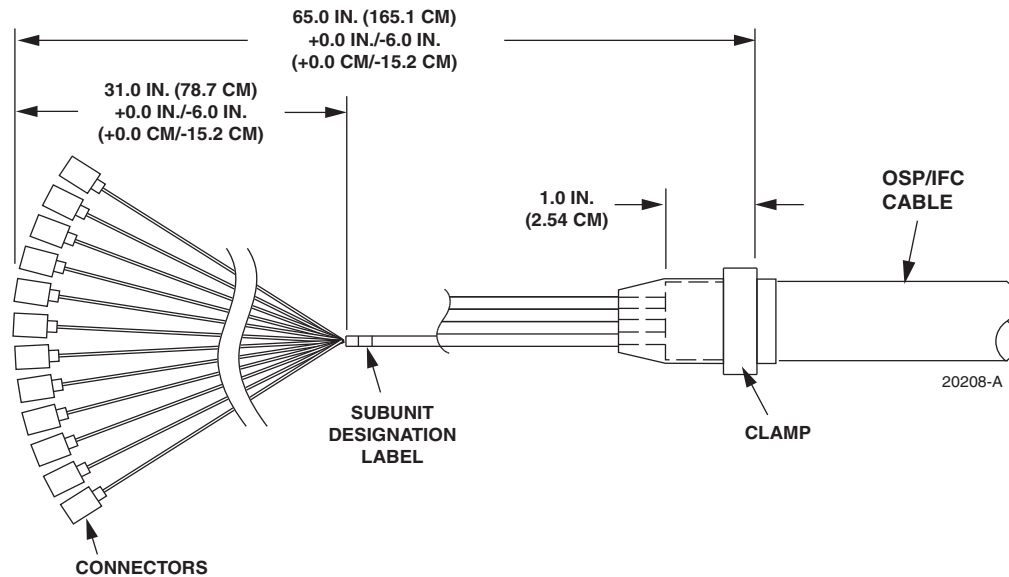

Figure 12. Cable Assembly Breakout Detail

## 6.2 Internal Cable Routing

A separate procedure is provided here for each different DIP configuration.

### 6.2.1 Termination (Universal Entry)

Cables routed into the tray for termination are normally pre-terminated individual cables (simplex or duplex patch cords). Refer to the following instructions.

1. Open tray fully and lock it using the lock open latch (see [Subsection 7.1 Opening the Tray](#)).
2. Route the cable along the rack to the 2RU FMT, as shown in [Figure 13](#).

► **Note:** The cable may be routed from either above or below the tray. It may be routed into the 2RU FMT from either the left or right side.

3. Secure the cable to the rack using local practice.
4. Route the cable into the fully-open tray through the cable guide as shown.

► **Note:** The sliding radius limiters must be in the position shown.

► **Note:** Before tying off the cable as shown, proceed with the next step below.

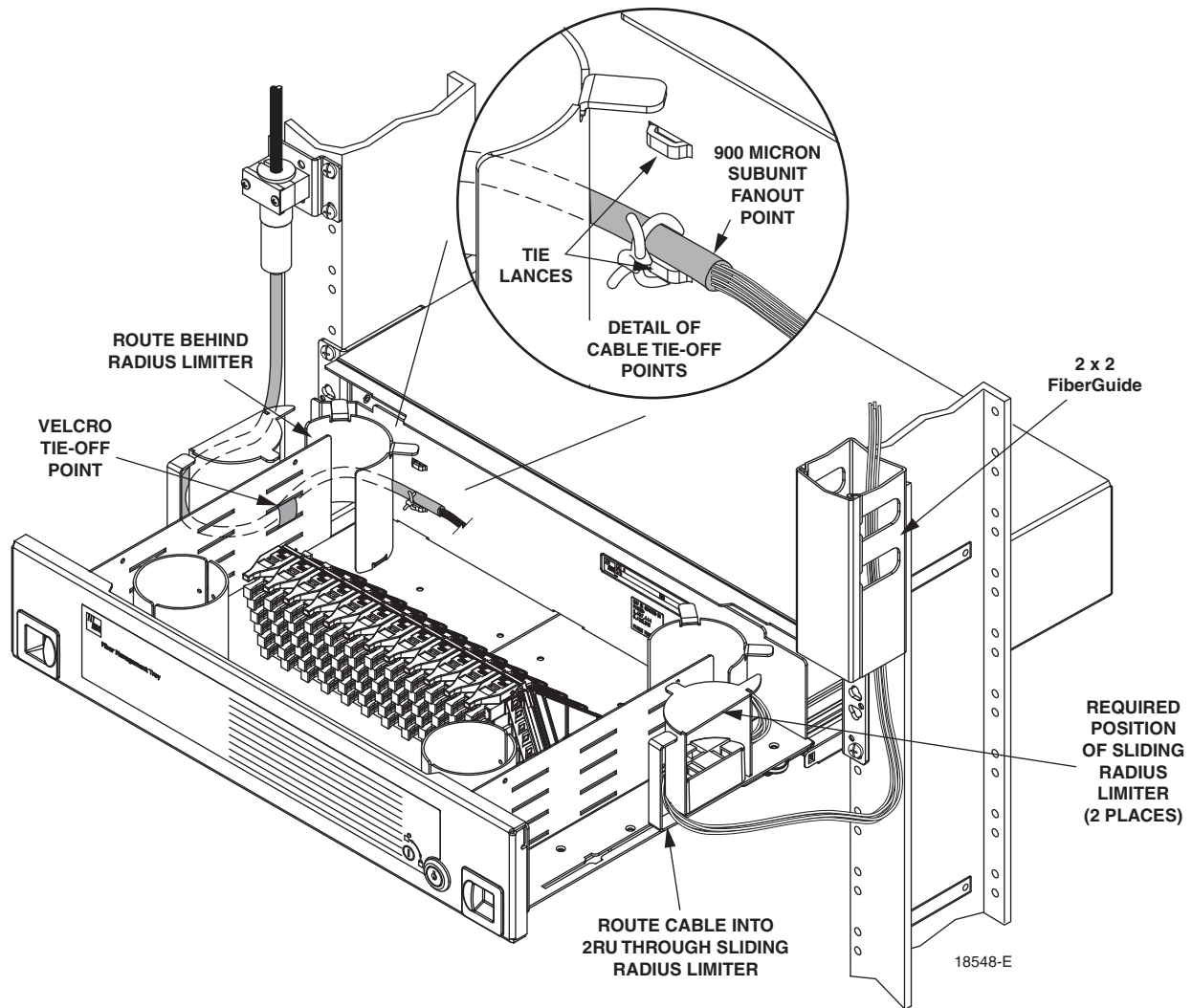

Figure 13. Securing Cables Within 72-Position Termination Tray

5. Route the cable within the tray as shown in [Figure 14](#). Note that there are different routings for cables being terminated at the front and rear of the adapters packs.



**Danger:** Infrared radiation is invisible and can seriously damage the retina of the eye. Do not look into the ends of any optical fiber. Do not look directly into the optical adapters of the adapter packs. Exposure to invisible laser radiation may result. An optical power meter should be used to verify active fibers. A protective cap or hood **MUST** be immediately placed over any radiating adapter or optical fiber connector to avoid the potential of dangerous amounts of radiation exposure. This practice also prevents dirt particles from entering the adapter or connector.

► **Note:** Always clean and inspect connectors and adapters before mating them. For guidelines, refer to the connector cleaning instructions, ADCP-90-159.

6. Secure the cables on the side and rear of the tray as shown in [Figure 13](#).



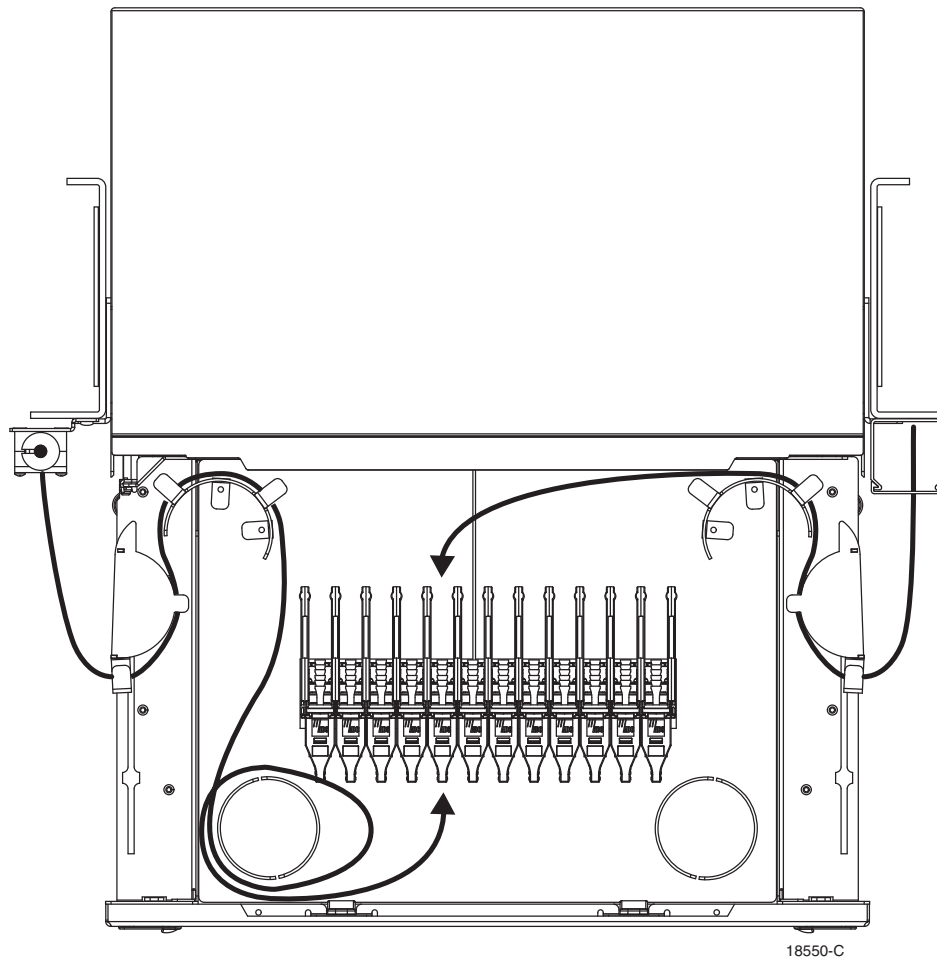

Figure 14. Cable Routing for 72-Position Termination Tray  
(Use Either This or Mirror Image)

7. To connect an individual cable connector to an adapter, lift up the release tab on top of the adapter pack and slide up the adapter pack (see [Figure 25](#) on page 28). Pull the dust cap straight out from the adapter and connect the cable connector to the adapter.

### 6.2.2 Termination (Left Entry for IFC)

Cables routed into the tray for termination are normally pre-terminated individual cables (simplex or duplex patch cords). Refer to the following instructions.

1. Open tray fully and lock it using the lock open latch (see [Subsection 7.1 Opening the Tray](#)).
  2. Route the cable along the rack to the 2RU FMT, as shown in [Figure 11](#) on page 14.
- **Note:** The cable may be routed from either above or below the tray on the left side.
3. Secure the cable to the rack using local practice.

4. Route the cable into the fully-open tray through the cable guide as shown.

► **Note:** Before tying off the cable as shown, proceed with the next step below.

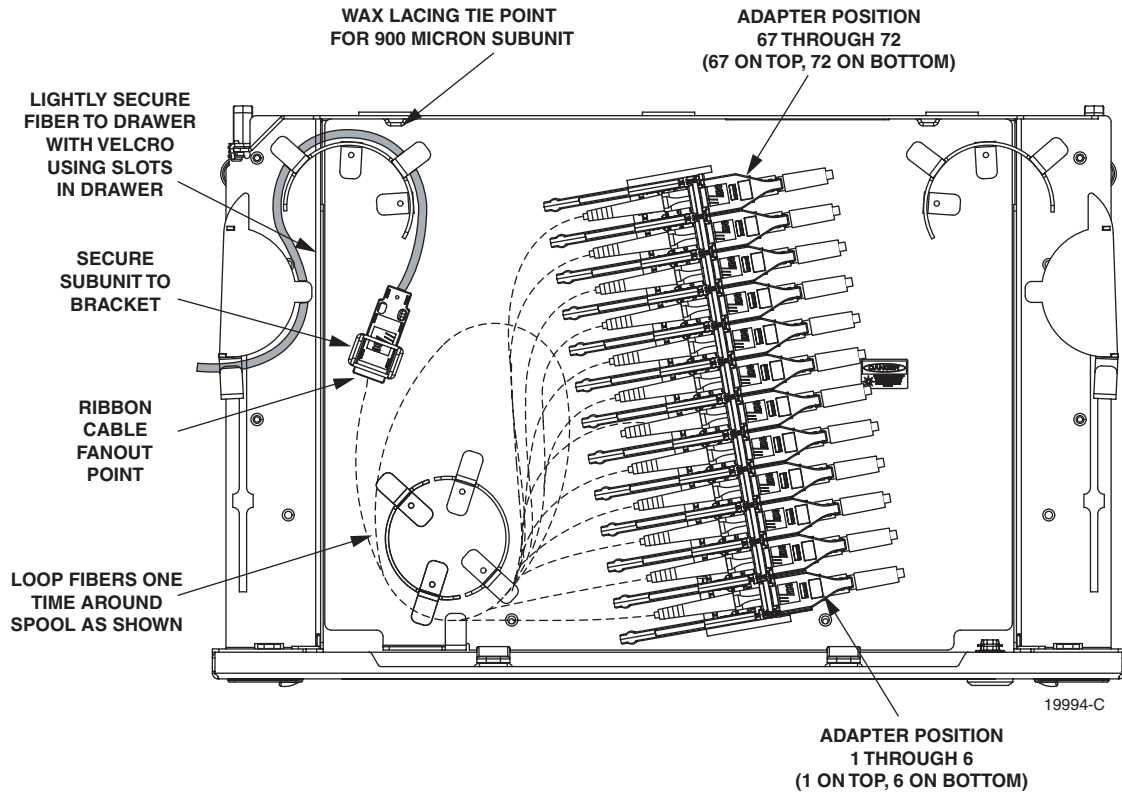

Figure 15. Cable Routing for 72-Position Termination Tray (Left Entry Only)

5. Route the cable within the tray as shown in [Figure 15](#). Note that there are different routings for cables being terminated at the front and rear of the adapters packs.



**Danger:** Infrared radiation is invisible and can seriously damage the retina of the eye. Do not look into the ends of any optical fiber. Do not look directly into the optical adapters of the adapter packs. Exposure to invisible laser radiation may result. An optical power meter should be used to verify active fibers. A protective cap or hood **MUST** be immediately placed over any radiating adapter or optical fiber connector to avoid the potential of dangerous amounts of radiation exposure. This practice also prevents dirt particles from entering the adapter or connector.

► **Note:** Always clean and inspect connectors and adapters before mating them. For guidelines, refer to the connector cleaning instructions, ADCP-90-159.

6. Secure the cables on the side and rear of the tray as shown in [Figure 15](#).

### 6.2.3 Micro-VAM

Cables routed into the micro-VAM tray are normally pre-terminated individual cables. Refer to the following instructions.

1. Open the tray fully and lock it using the lock open latch (see [Subsection 7.1 Opening the Tray](#)).
2. Route the cable along the rack to the tray as shown in [Figure 16](#) on page 19.

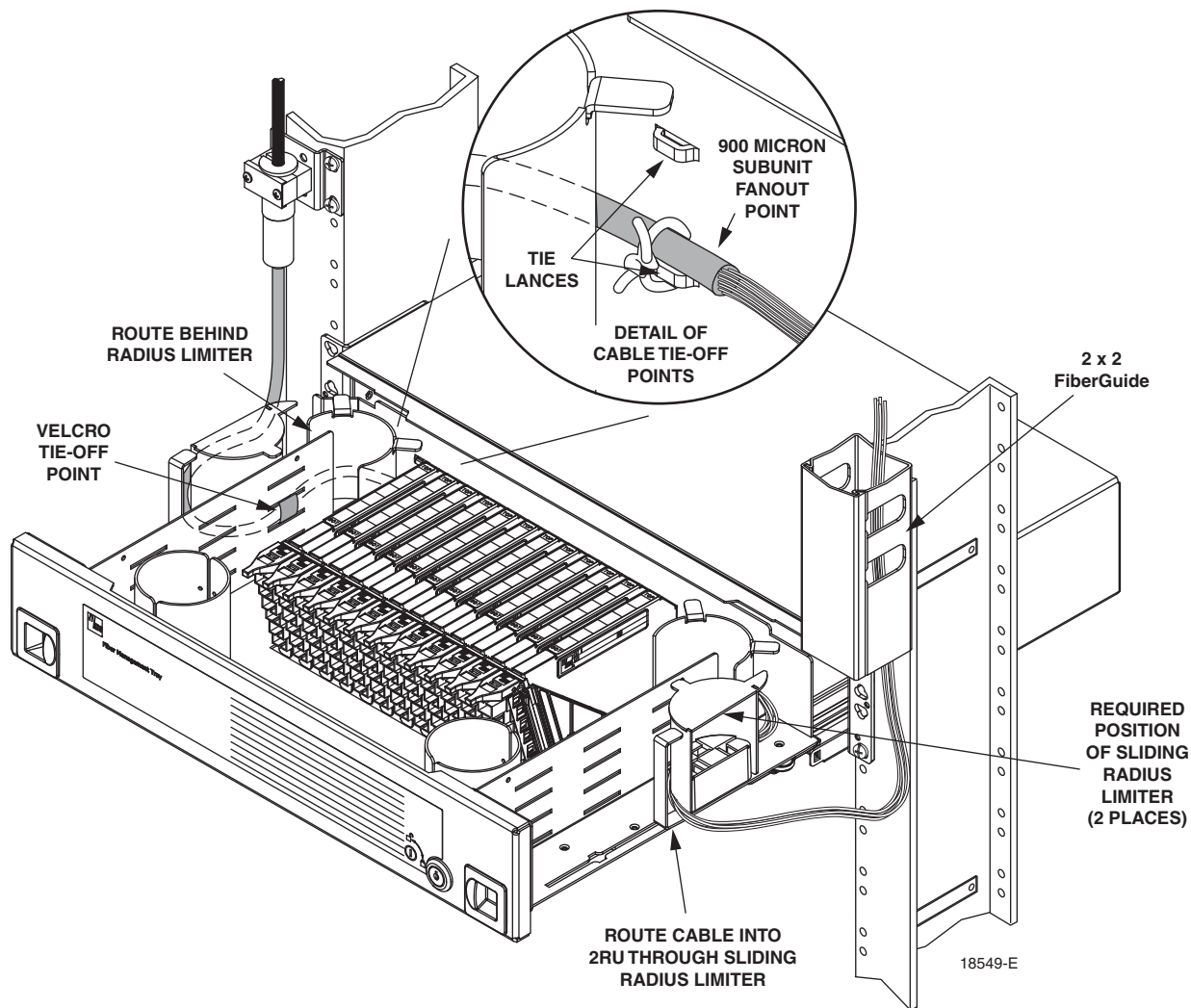

Figure 16. Securing Cables Within 72-Position Micro-VAM Tray

► **Note:** The cable may be routed from either above or below the tray. The cable may be routed into the tray from either the left or right side or from both sides

3. Secure the cable to the rack using local practice.
4. Route the cable into the fully-open tray through the cable guide as shown.

- ▶ **Note:** The sliding radius limiters must be in the position shown.
  - ▶ **Note:** Before tying off the cable as shown, proceed with the next step below.
5. Route the cables within the tray as shown in [Figure 17](#) for entry from both sides or as shown in [Figure 18](#) for entry from either left or right side. (Left side entry is shown. Routing for right side entry is a mirror image of the routing shown.) All cable are terminated on the front of the micro-VAMs.

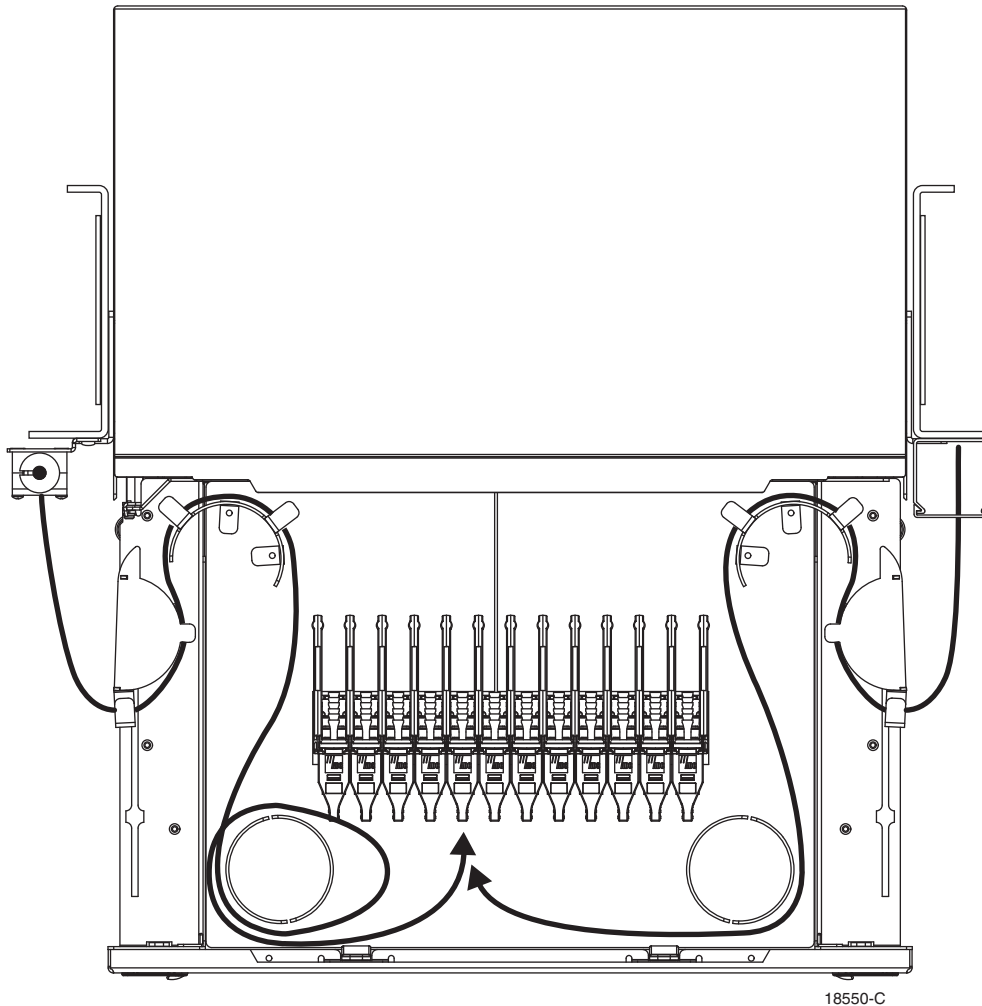

Figure 17. Cable Routing for 72-Position Micro-VAM Tray (Enter From Both Sides)



**Danger:** Infrared radiation is invisible and can seriously damage the retina of the eye. Do not look into the ends of any optical fiber. Do not look directly into the optical adapters of the adapter packs. Exposure to invisible laser radiation may result. An optical power meter should be used to verify active fibers. A protective cap or hood **MUST** be immediately placed over any radiating adapter or optical fiber connector to avoid the potential of dangerous amounts of radiation exposure. This practice also prevents dirt particles from entering the adapter or connector.

- ▶ **Note:** Always clean and inspect connectors and adapters before mating them. For guidelines, refer to ADCP-90-159.
- 6. To connect an individual cable connector to a micro-VAM, lift up the release tab on top of the micro-VAM and slide the micro-VAM upward (see [Figure 26](#) on page 28). Pull the micro-VAM dust cap straight out and connect the connector to the micro-VAM port.
- 7. Secure the cables on the side and rear of the tray as shown in [Figure 16](#) on page 19.

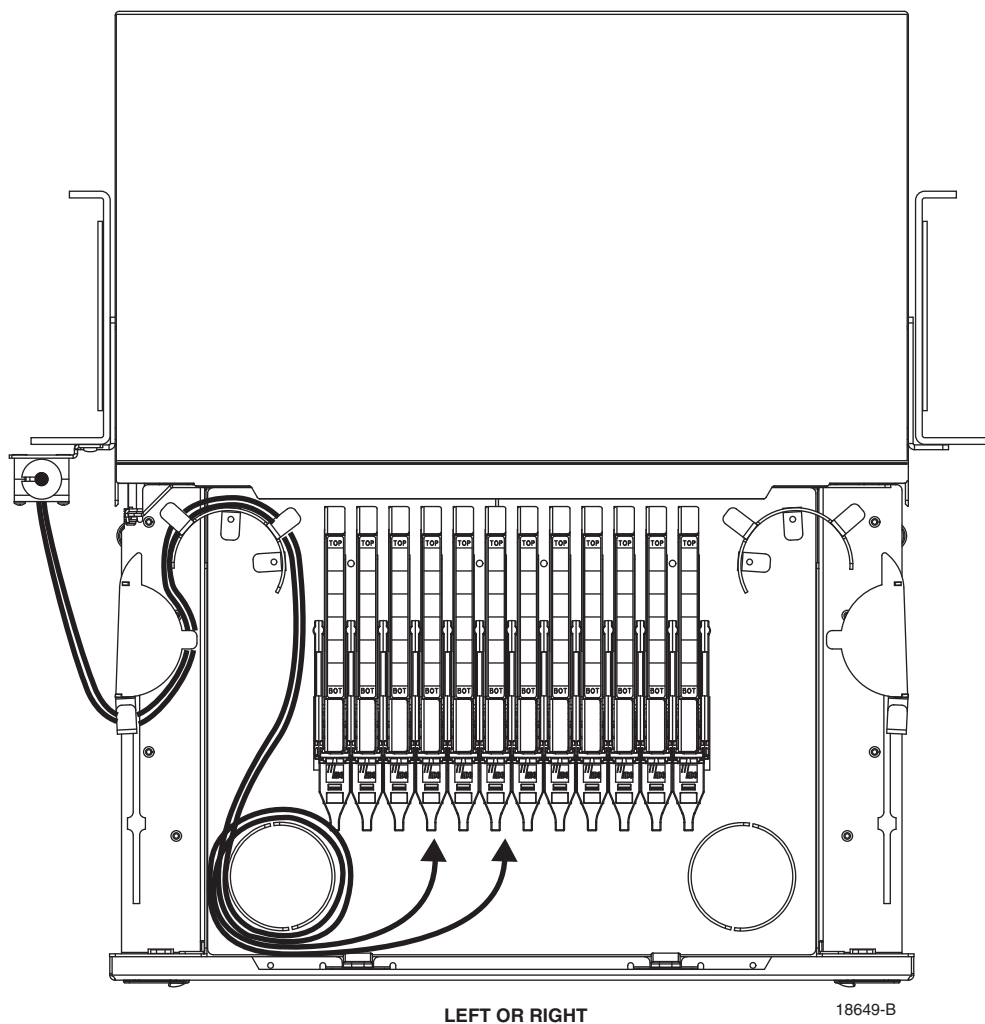

Figure 18. Cable Routing for 72-Position Micro-VAM Tray  
Left or Right Entry (Use Either This or Mirror Image)

#### 6.2.4 48-Position Termination/Splice

Cables routed into the tray for splicing or termination are normally multifiber cable assemblies. Cables to be spliced will be bare-ended. Cables to be terminated will be pre-terminated. The 2RU FMT will also have factory-installed, internal pigtailed between splice tray and connector bulkhead. Refer to the following instructions.

1. Open the tray fully and lock it using the lock open latch (see [Subsection 7.1 Opening the Tray](#)).
  2. Route cables along the rack to the 2RU FMT, as shown in [Figure 19](#). Route cable to be spliced on the left side of the rack. Route cable to be terminated on the right side of the rack.
- **Note:** The cables may be routed from either above or below the tray.
3. Secure the cables to the rack using local practice.

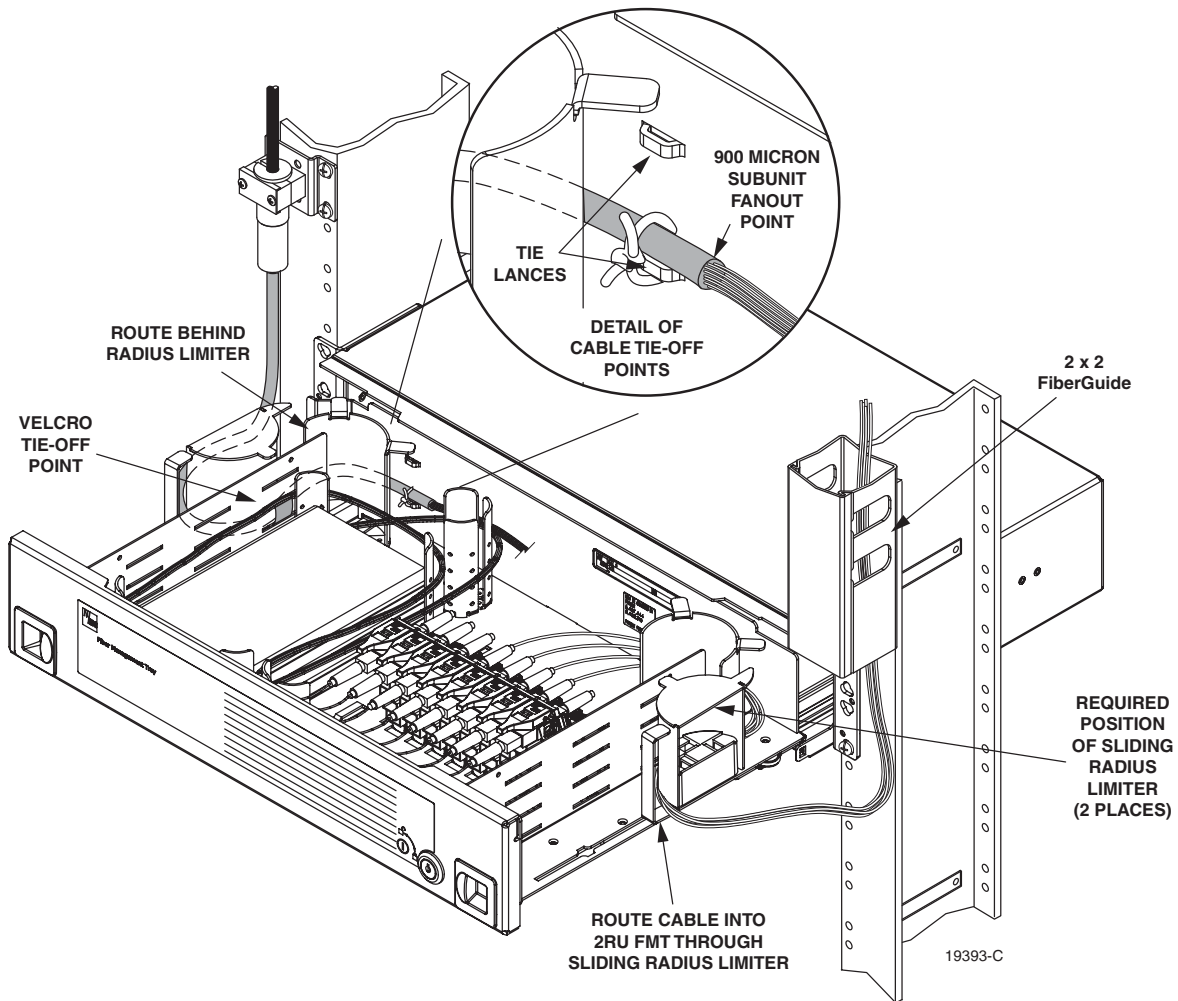

Figure 19. Securing Cables Within 48-Position Termination/Splice Tray

4. Route the cables into the fully-open tray through the cable guides as shown.
- **Note:** The sliding radius limiters must be in the position shown.
5. Route the cables within the tray as shown in [Figure 20](#).
- **Note:** Always clean and inspect connectors and adapters before mating them. For guidelines, refer to the connector cleaning instructions, ADCP-90-159.



**Danger:** Infrared radiation is invisible and can seriously damage the retina of the eye. Do not look into the ends of any optical fiber. Do not look directly into the optical adapters of the adapter packs. Exposure to invisible laser radiation may result. An optical power meter should be used to verify active fibers. A protective cap or hood **MUST** be immediately placed over any radiating adapter or optical fiber connector to avoid the potential of dangerous amounts of radiation exposure. This practice also prevents dirt particles from entering the adapter or connector.

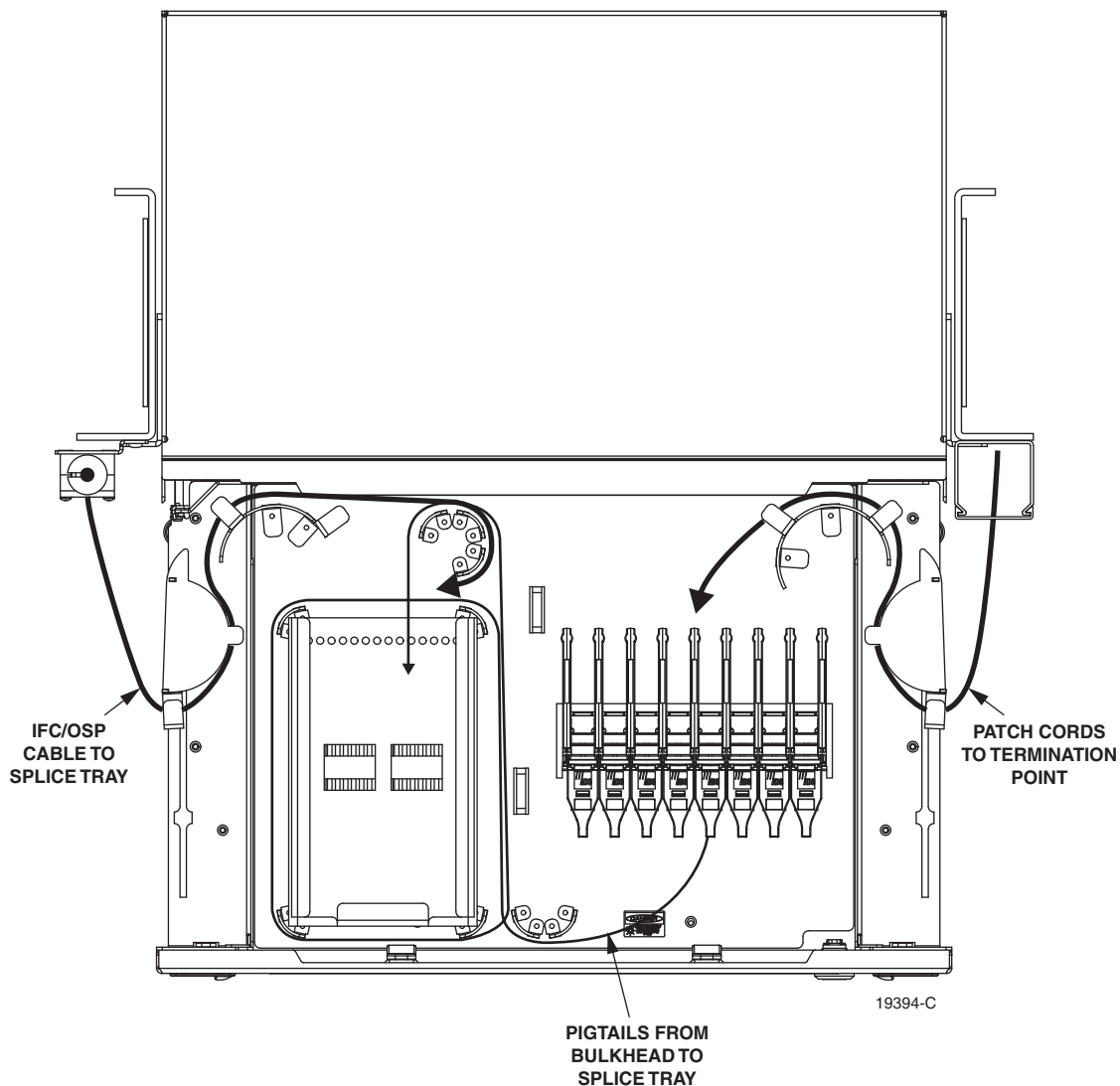

Figure 20. Cable Routing for 48-Position Termination/Splice Tray

6. Route the cables within the splice tray as shown in [Figure 21](#).
7. Secure the cables on the side and rear of the tray as shown in [Figure 19](#) on [page 22](#).
8. To connect an individual cable connector to an adapter, lift up the release tab on top of the adapter pack and slide up the adapter pack (see [Figure 25](#) on [page 28](#)). Pull the dust cap straight out from the adapter and connect the cable connector to the adapter.

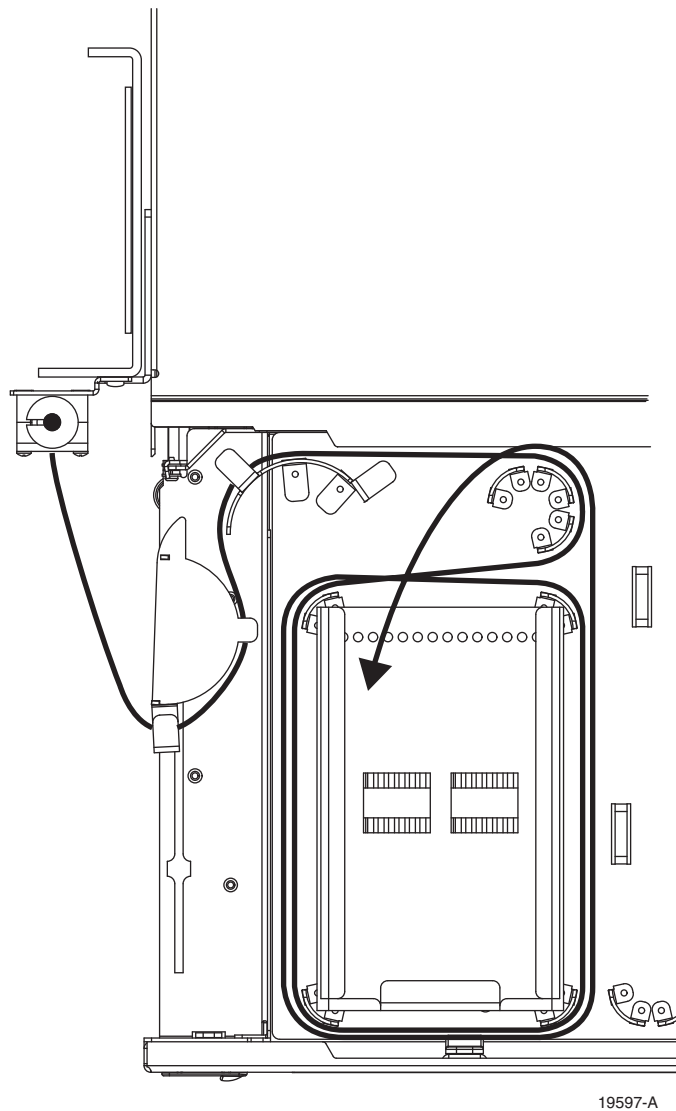

Figure 21. Routing Within Splice Tray

### 6.2.5 Bulk Storage

Cable routed into the tray are typically 1.66mm patch cords. To store the patch cords in a bulk storage tray, refer to the following instructions.

1. Open the tray fully and lock it using the lock open latch (see [Subsection 7.1 Opening the Tray](#)).
2. Route the patch cords along the rack to the 2RU FMT, as shown in [Figure 22](#). Route the patch cords in from either side of the tray.

► **Note:** The cables may be routed from either above or below the tray.



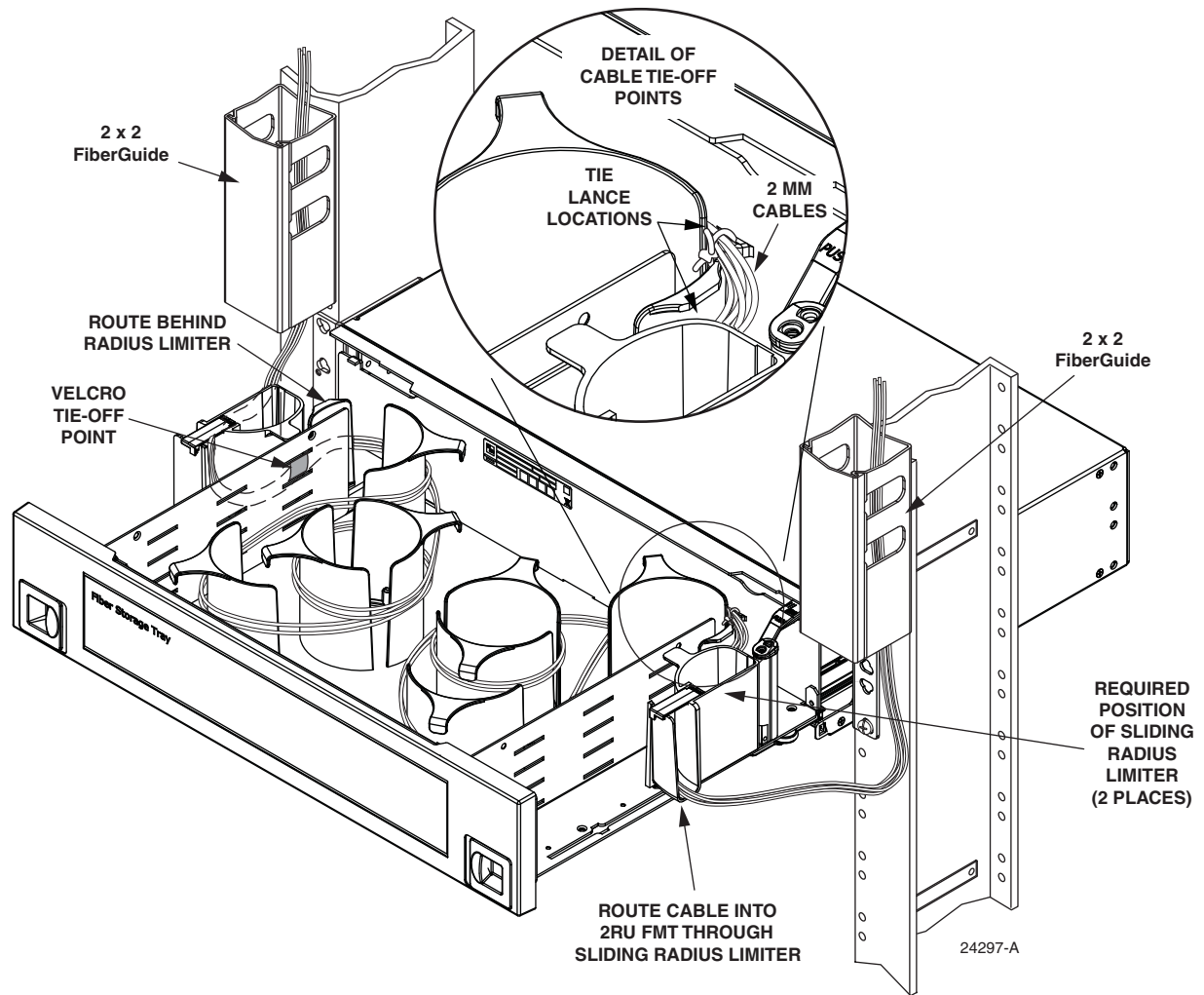

Figure 22. Routing Patch Cords into Bulkhead Storage Tray

3. Secure the patch cords to the rack using local practice.
4. Route the patch cords into the fully-open tray through the cable guides as shown.
- **Note:** The sliding radius limiters must be in the position shown.
5. Route the patch cords within the tray as shown in [Figure 23](#).

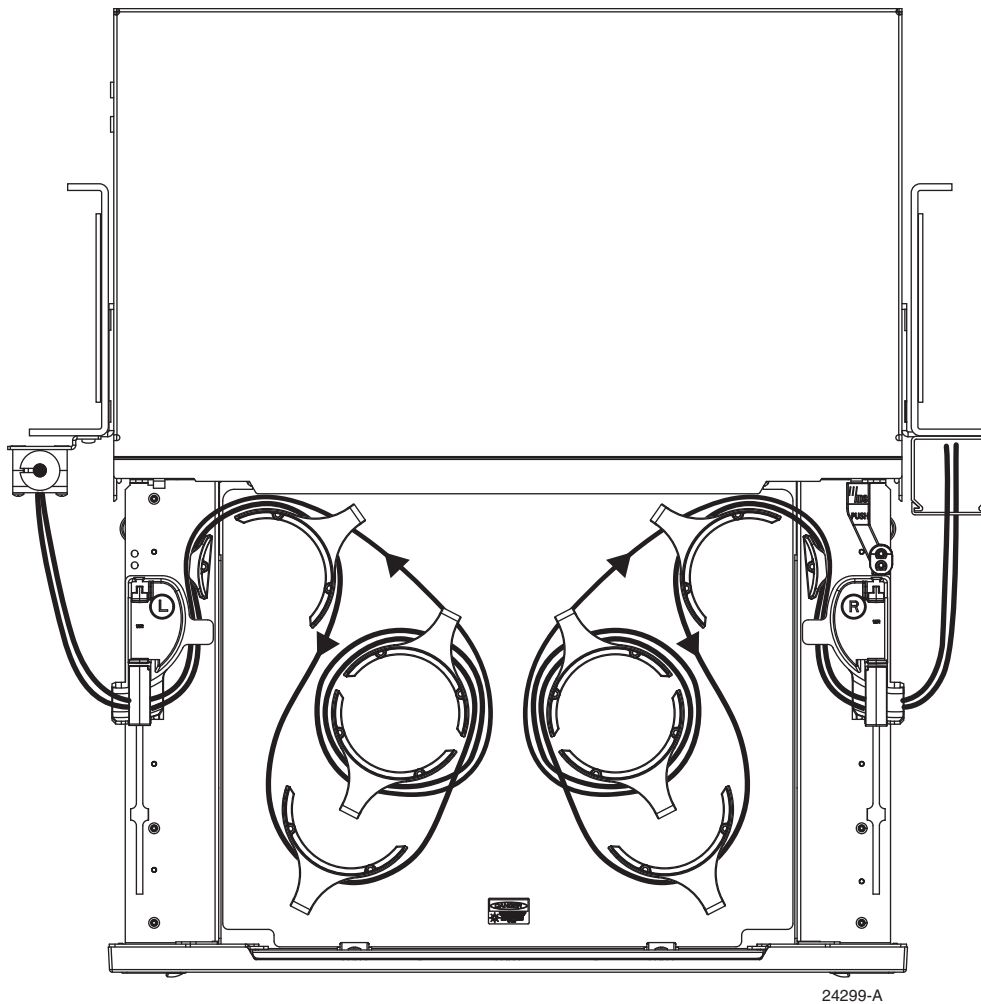

Figure 23. Cable Routing for Bulk Storage FMT Panel

6. Route the patch cords within the tray as shown in [Figure 23](#).

► **Note:** For maximum storage, balance the load between the two sides.

## 7 OPERATION

Operation consists of opening the tray, connecting patch cords to adapters or micro-VAMs, and closing the tray. When routing patch cords, refer to the routing diagrams provided in [Section 6](#).



**Danger:** Infrared radiation is invisible and can seriously damage the retina of the eye. Do not look into the ends of any optical fiber. Do not look directly into the optical adapters of the adapter packs. Exposure to invisible laser radiation may result. An optical power meter should be used to verify active fibers. A protective cap or hood **MUST** be immediately placed over any radiating adapter or optical fiber connector to avoid the potential of dangerous amounts of radiation exposure. This practice also prevents dirt particles from entering the adapter or connector.

## 7.1 Opening the Tray

To open the 2RU FMT tray, slide the release tabs inward with both hands and pull the drawer straight out as far as it goes. While working in the tray, lock tray in position as shown in [Figure 24](#). Press latch down to unlock tray and push closed.



**Caution:** Placing a load in excess of 12 pounds (5.4 kg) onto an open tray will result in misalignment or damage to the tray.

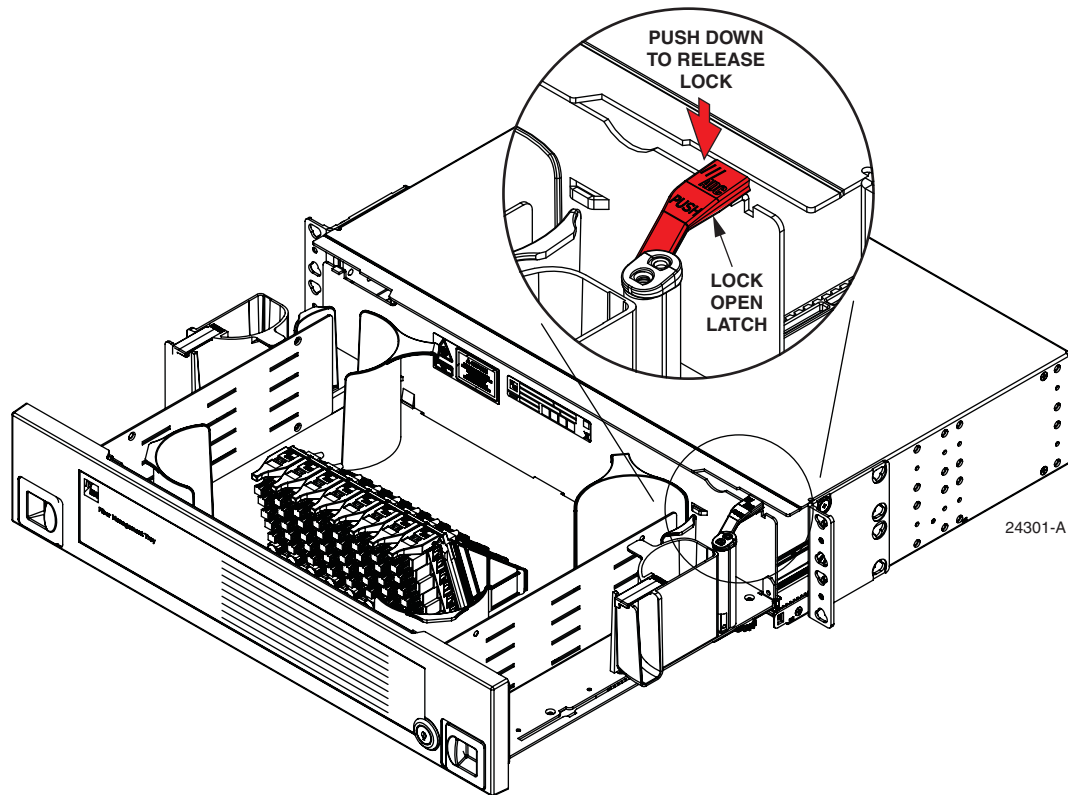

Figure 24. Tray Locked in Open Position

## 7.2 Sliding Adapter Packs

To access a sliding adapter pack ([Figure 25](#)):

1. Route the patch cord into the tray as shown in the appropriate diagram in [Section 6](#).

2. Lift up the release tab and slide up the adapter pack.
- **Note:** Always clean and inspect connectors and adapters before mating them. For guidelines, refer to ADCP-90-159.
3. Pull the dust cap straight out.
  4. Connect the patch cord connector to the adapter and slide the adapter pack back down.
  5. Close the tray as described in [Subsection 7.4 Closing the Tray](#).

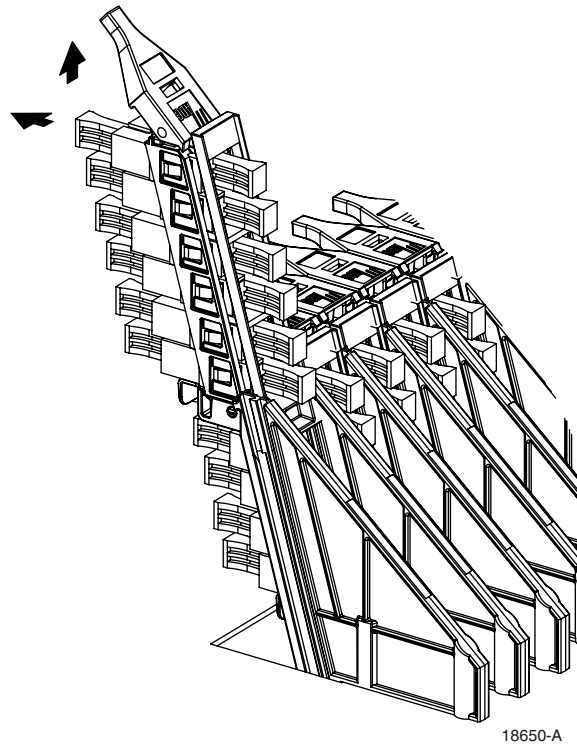

Figure 25. Removing Dust Cap From Standoff Style Adapter Pack

### 7.3 Micro-VAMs

To access a micro-VAM ([Figure 26](#)):

1. Route the patch cord into the tray as shown in the appropriate diagram in [Section 6](#).
  2. Lift up the release tab and slide up the micro-VAM.
- **Note:** Always clean and inspect connectors and adapters before mating them. For guidelines, refer to ADCP-90-159.
3. Pull the dust cap straight out.
  4. Connect the patch cord connector to the desired adaptor.
  5. Close the tray as described in [Subsection 7.4 Closing the Tray](#).

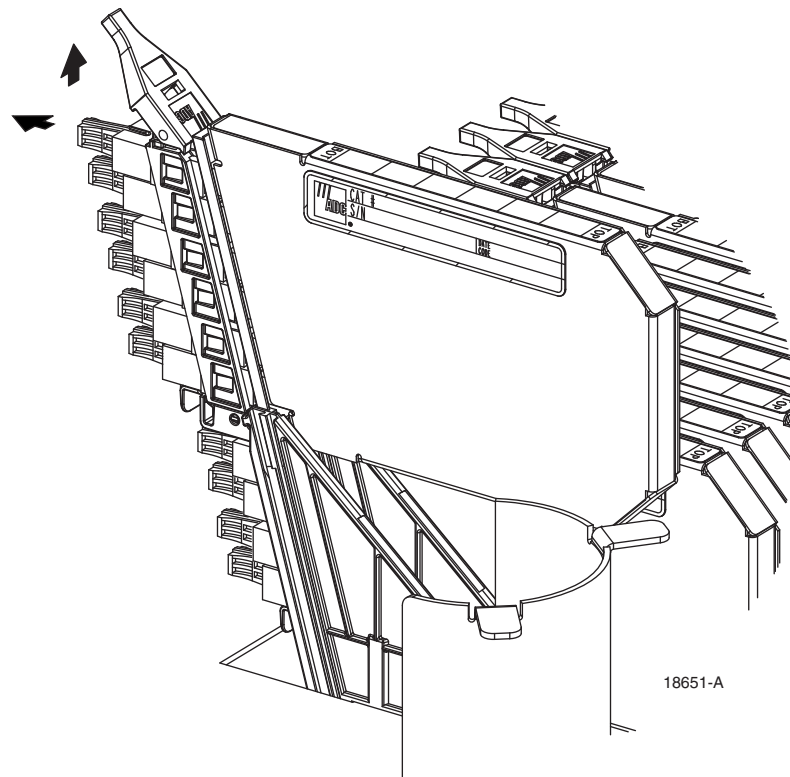

Figure 26. Accessing a Micro-VAM

## 7.4 Closing the Tray

Close the tray using the following procedure:

1. Fully lower and seat all connector or micro-VAM 6-packs.
2. Assure that all cables and fibers are properly secured and located below the top surface of the tray.
3. Release the lock open latch (“unlocked position” shown in [Figure 24 on page 27](#)).
4. Slowly close the tray, observing that no fiber kinks or macro bends occur as a result of fiber routing.
5. Latch tray shut using the lock open latch (“locked position” shown in [Figure 24 on page 27](#)).

## 8 TECHNICAL ASSISTANCE

Contact the **Technical Assistance Center (TAC)** for technical question. Call 800.830.5056 or send an email to [TAC.Americas@commscope.com](mailto:TAC.Americas@commscope.com).