

4

3

2

1

NOTES:

- 1. GENERAL
 - 1.1 ALL METRIC DIMENSIONS ARE IN BRACKETS.
 - 1.2 MARK PART WITH IDENTIFICATION NUMBER
- 3. MANUFACTURING/SPECIAL REQUIREMENTS
 - 3.1 TIGHTEN ALL BOLTS SECURING FLAT PLATES BY THE TURN-OF-NUT METHOD. TIGHTEN ALL U-BOLTS USING TURN-OF-NUT METHOD WITH ATTENTION TO LEAVE EQUAL DISTANCE AND EQUAL FORCE ON EACH LEG OF THE U-BOLT.
- 4. TEST
- 5. PACKAGING
 - 5.1 PACKAGING SHALL MEET COMMSCOPE REQUIREMENTS PER DOCUMENT IS-PL-3005.
 - 5.2 PRINTED DOCUMENT TO BE PLACED INSIDE POLYBAG AND THEN IN SHIPPING CONTAINER.
 - 5.3 EXTRA HARDWARE MAYBE SUPPLIED, BAGGED AND SHIPPED.

REVISIONS				
REV.	ECN	DESCRIPTION	BY	DATE
A	11504	INITIAL RELEASE	RJC	4/9/2021
B	15087	CHANGE LOCATION OF TIE BACK	ZX1005	22/9/2021

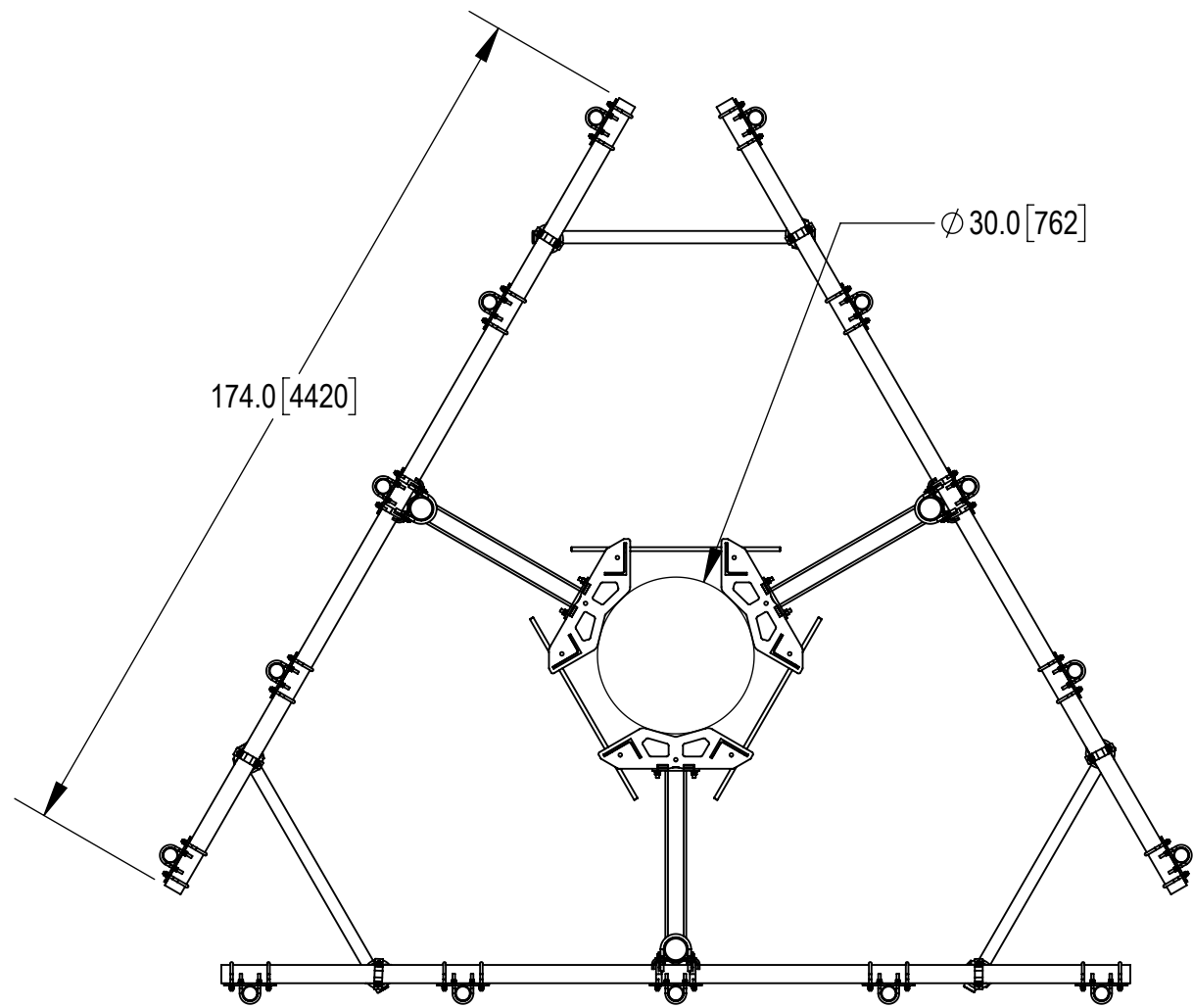
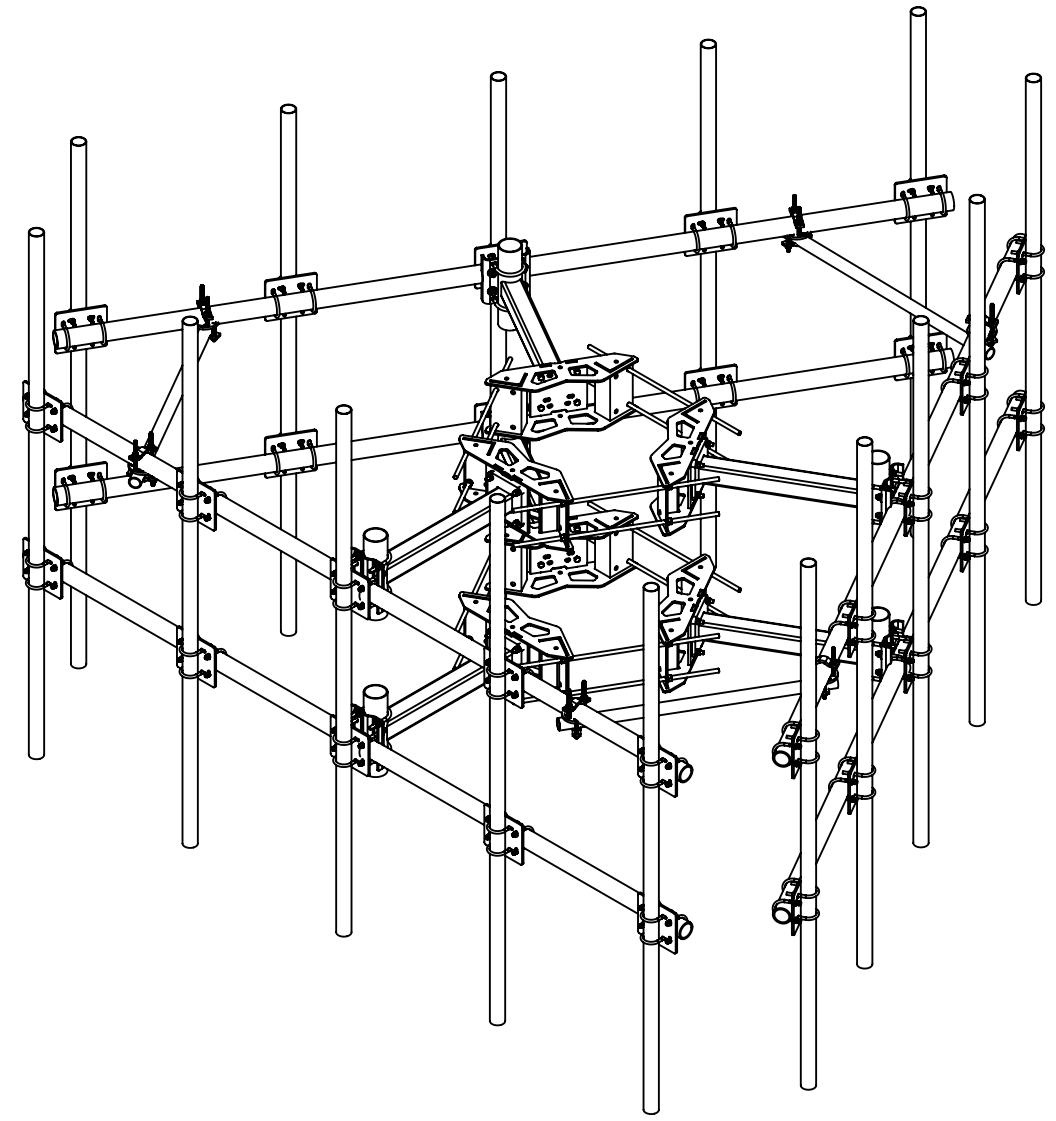
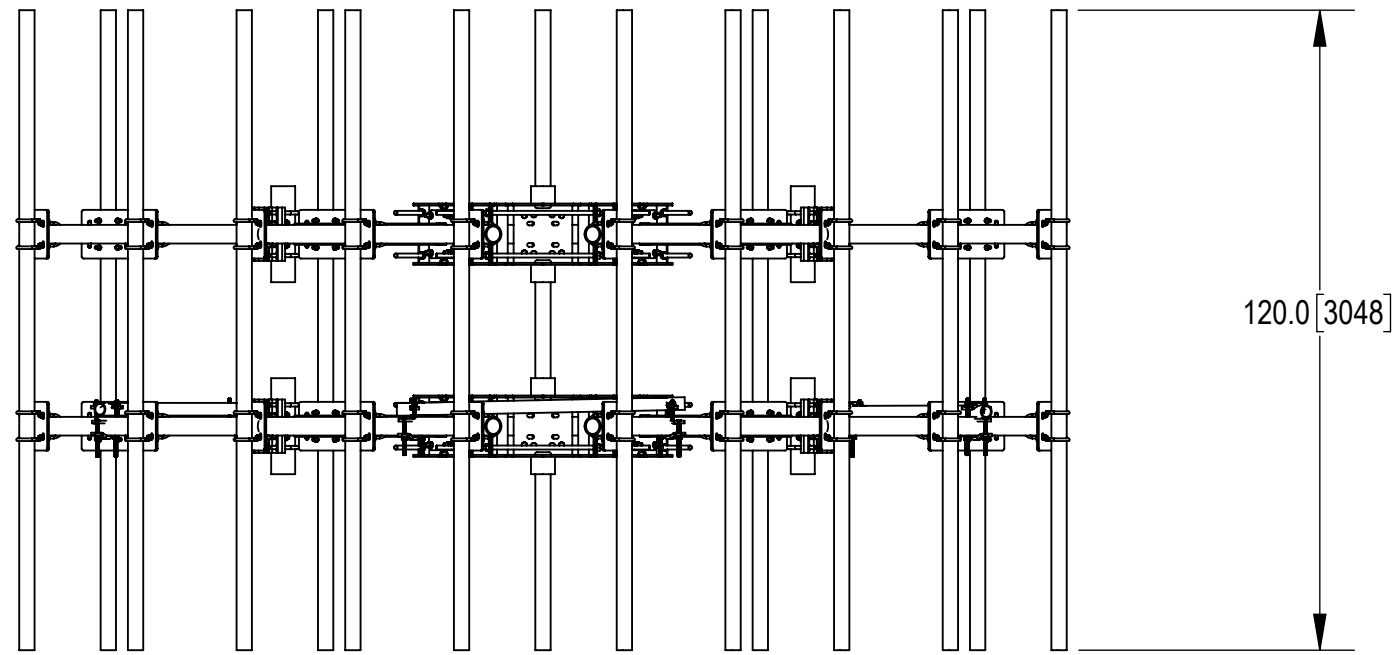

DENSITY		lbs/in ³
MASS	1326.954	lbs
VOLUME	13956.452	in ³
SURFACE AREA	76526.524	in ²
HEIGHT		
LENGTH		
WIDTH		

COMMSCOPE, INC. OF NORTH CAROLINA										
TOLERANCES					SAP MATERIAL MASTER					
1 PLACE .X ± 0.1		3 PLACE .XXX ± 0.010			MC-KD14M-15-WLL					
2 PLACE .XX ± 0.03		ANGLES ± 0.5°			MATERIAL SEE BOM					
FINISH GALV A123					MATERIAL SEE BOM					
UNLESS OTHERWISE SPECIFIED DIMENSIONS ARE IN INCHES INTERPRET PER ANSI Y 14.5M-1994	CE	RJC	04/09/21	MONOPOLE, DBL T-ARM, 14' FACE, (15) 120" AP						
	RW	ZX1005	10/27/2021							
	AD	BCROSS	11/03/2021							
	RE	HDAI	11/03/2021							
	ECN	15087PC								
SCALE		DOCUMENT NO.								
1:48		MC-KD14M-15-WLL								
SIZE	Auth Group	INSL	MODEL			DRAWING				SHEET
C			VERSION	STATUS	REVISION	VERSION	STATUS	REVISION	1 OF 3	
			01	RE	B	01	RE	B		

4

3

2

1

4

3

2

1

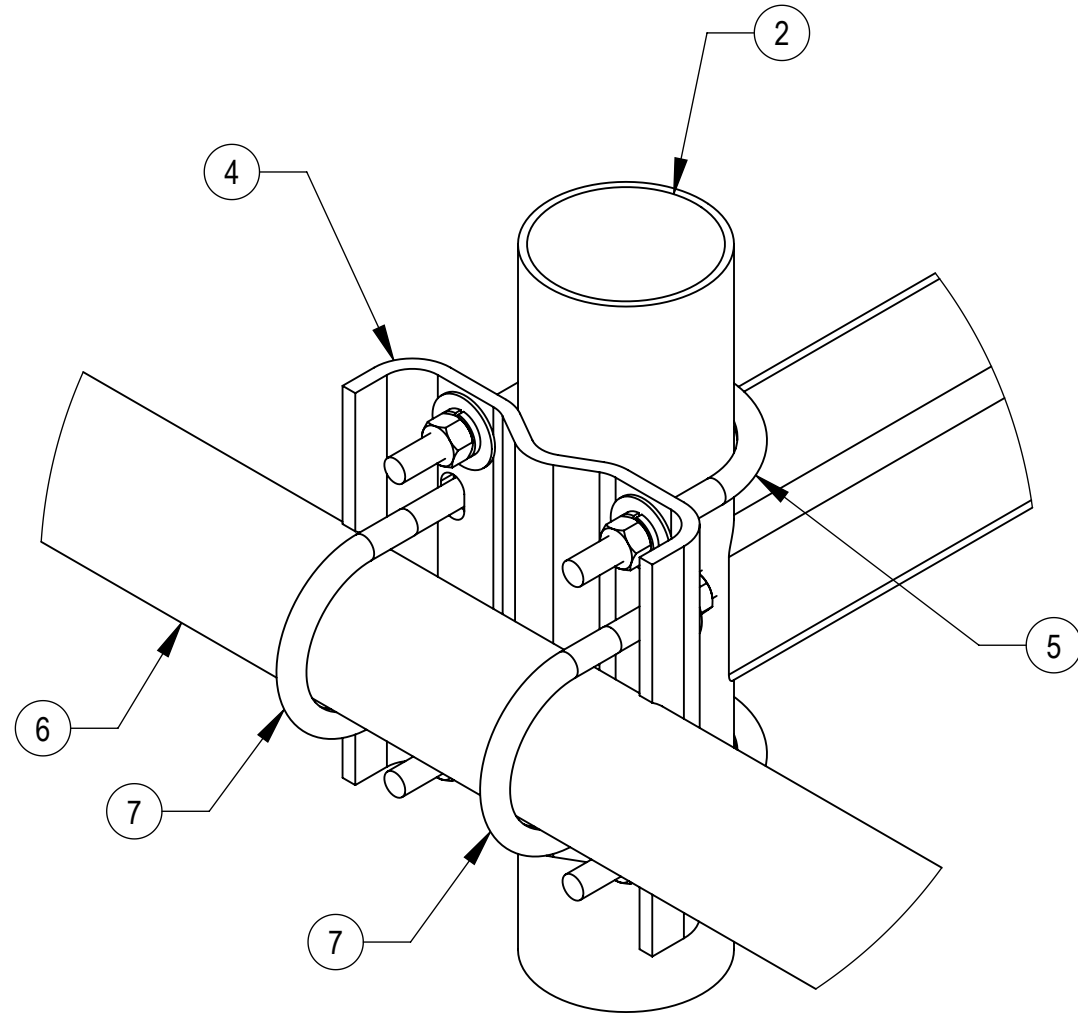

NOTES:

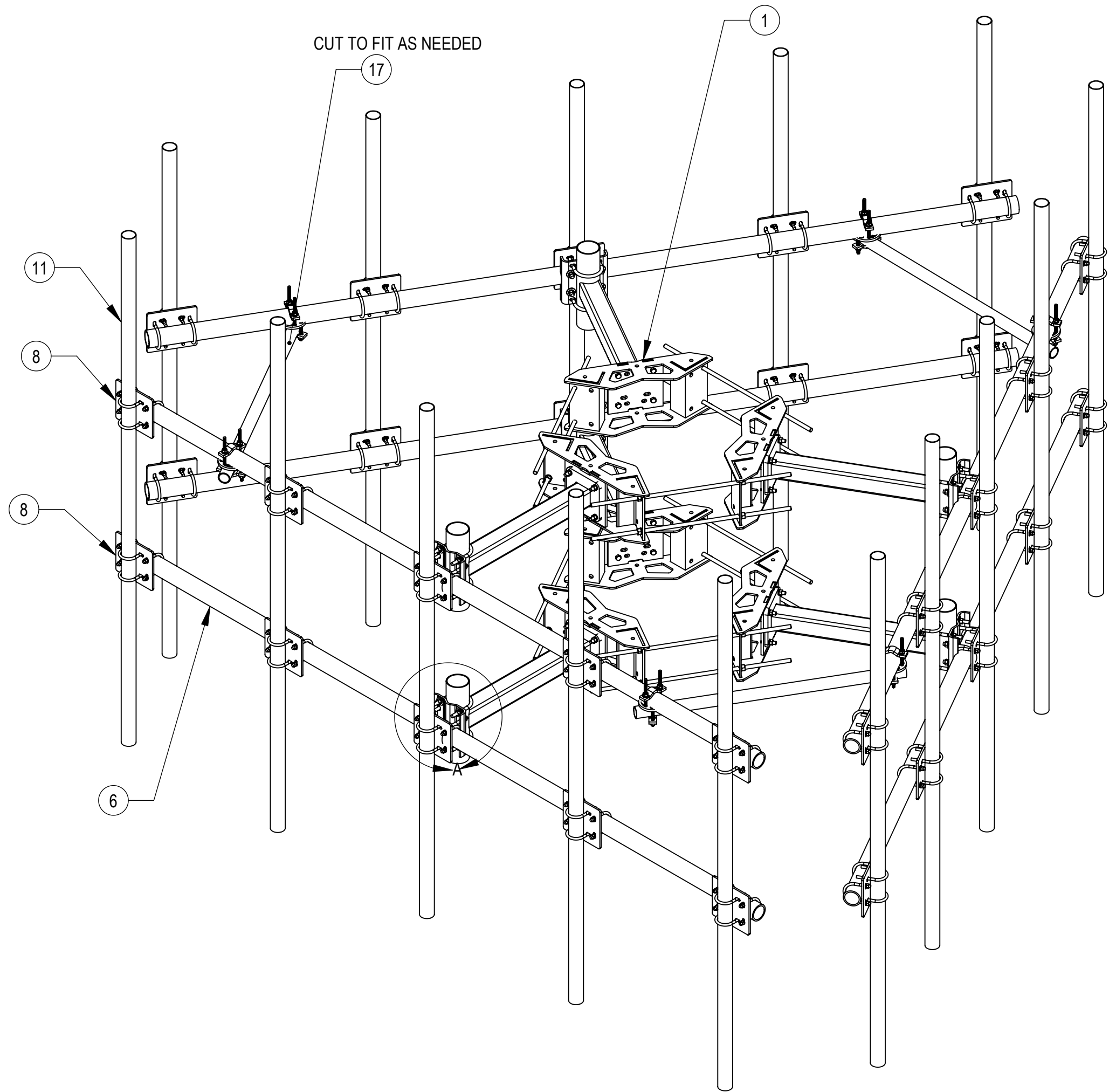

DETAIL A
SCALE 1:4



ITEM NO.	PART NUMBER	DESCRIPTION	QTY.
1	MC-RM1550-3	12" - 50" OD RINGMOUNT	2
2	MT197.01	36" SINGLE SUPPORT ARM	6
3	GB-05245	5/8" X 2-1/2" GALV BOLT KIT	24
4	MT216.13	CENTER BRACKET	6
5	GUB-5456	5/8" X 4-5/8" X 6 1/2" GALV U-BOLT	12
6	mt547174300	PIPE,PLAIN-END GALV 3-1/2" X 174" SCH 80	6
7	GUB-53560	5/8" X 3-5/8" X 6" GALV U-BOLT	12
8	XP3030.01	CROSSOVER PLATE Ø 3-1/2" O.D. TO	30
9	GUB-4355	1/2" X 3-5/8" X 5" GALV U-BOLT	60
10	GUB-4352	1/2" X 3" X 5-1/4" GALV U-BOLT	60
11	MT546120120	2.88 OD X .120" WALL X 120" LONG PIPE	15
12	XP-R	CROSSOVER PLATE, ROUND, UP TO 3.5" OD	6
14	GUB-4240	1/2" X 2-1/2" X 4" GALV U-BOLT	6
17	MT-651	PLAIN END PIPE, 2 3/8" OD X 72"	3

COMMSCOPE, INC. OF NORTH CAROLINA				
TITLE MONOPOLE, DBL T-ARM, 14' FACE, (15) 120" AP				
SIZE C	SCALE 1:20	DOCUMENT NO. MC-KD14M-15-WLL		
 		DRAWING		SHEET 2 OF 3
		VERSION 01	STATUS RE	

© 2021 CommScope, Inc. Confidential

4

3

2

1



D

D

C

C

B

B

A

A

4

3

2

1

NOTES:

14'6" FACE MODELS: Ø 15"-50" POLE

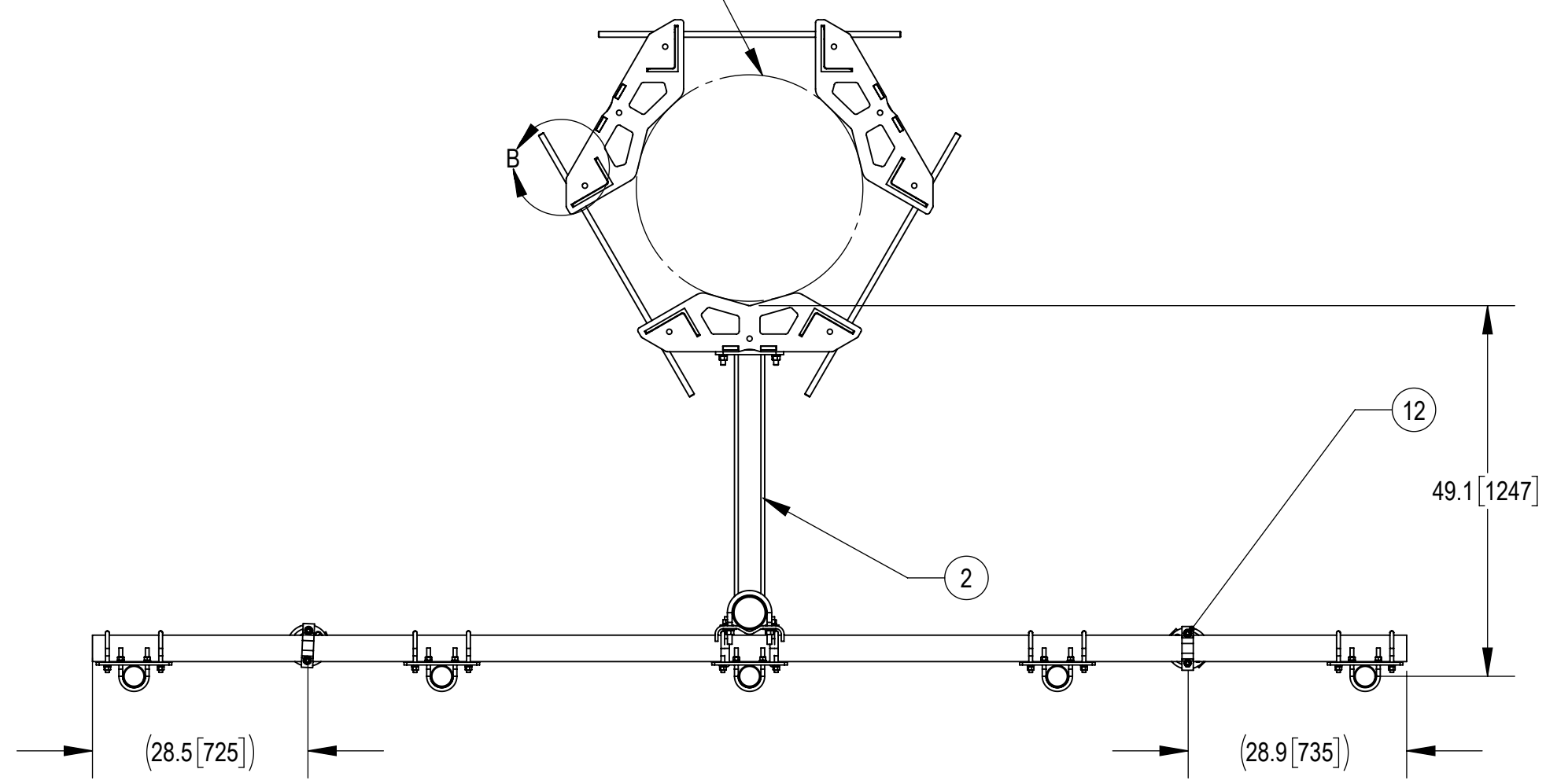

ALLOWABLE TIEBACK ANGLE

±15 DEGREES VERTICAL
±25 DEGREES HORIZONTAL

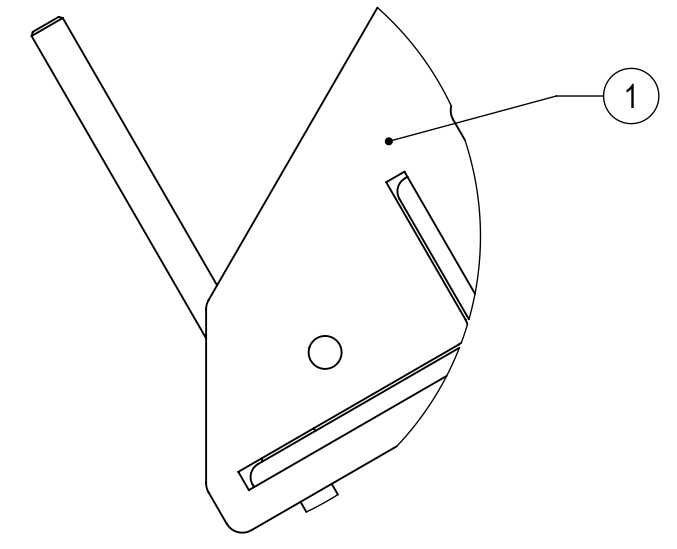
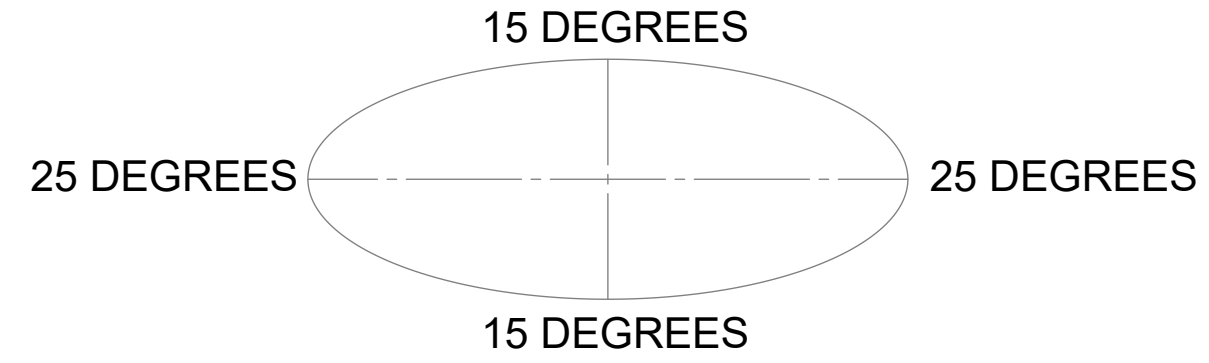

DETAIL B
SCALE 1:4

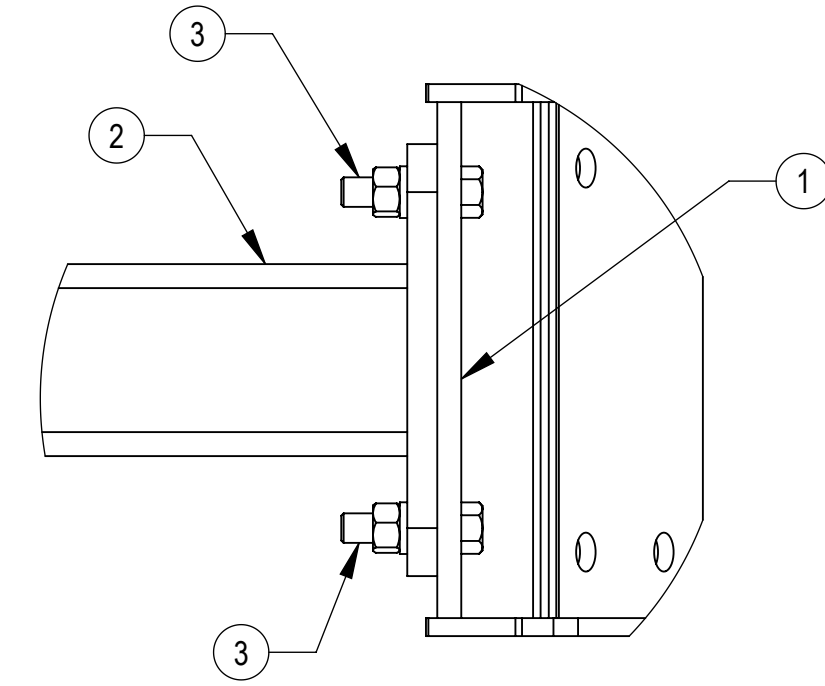

DETAIL C
SCALE 1:4

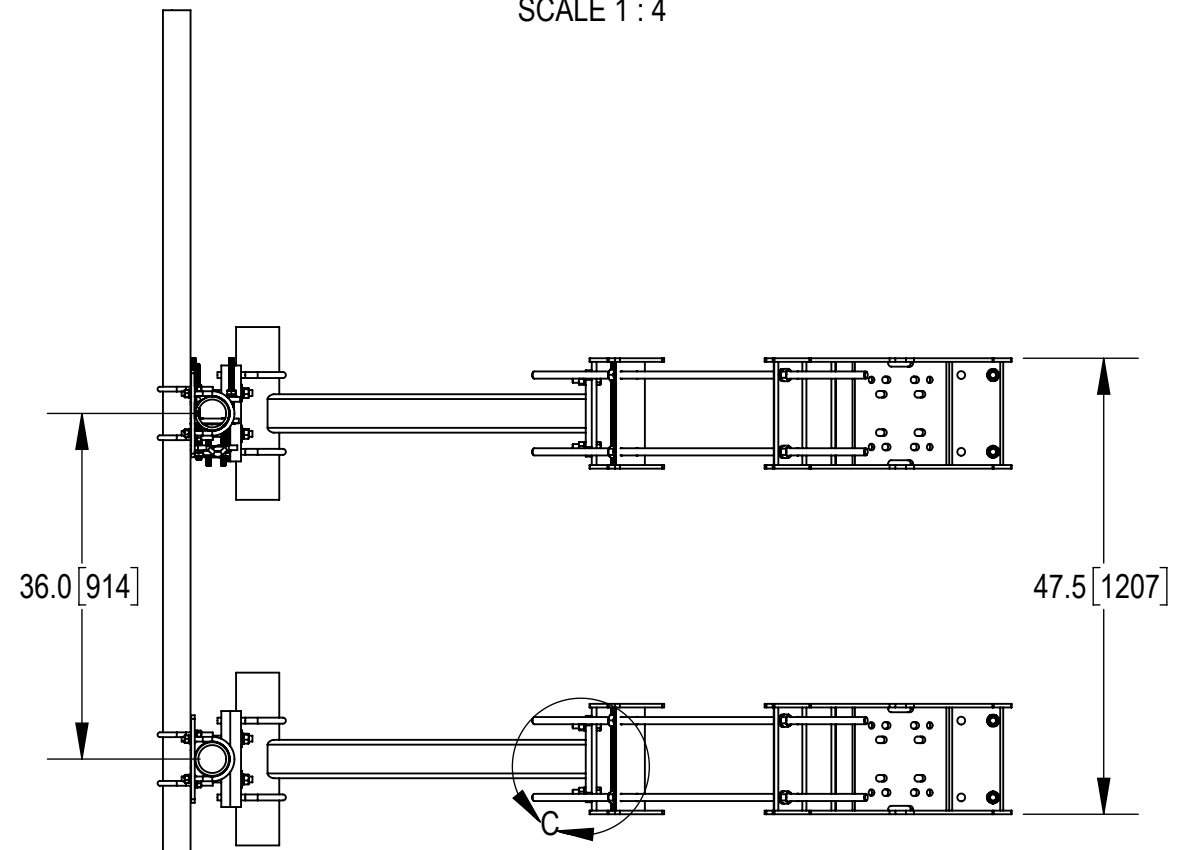
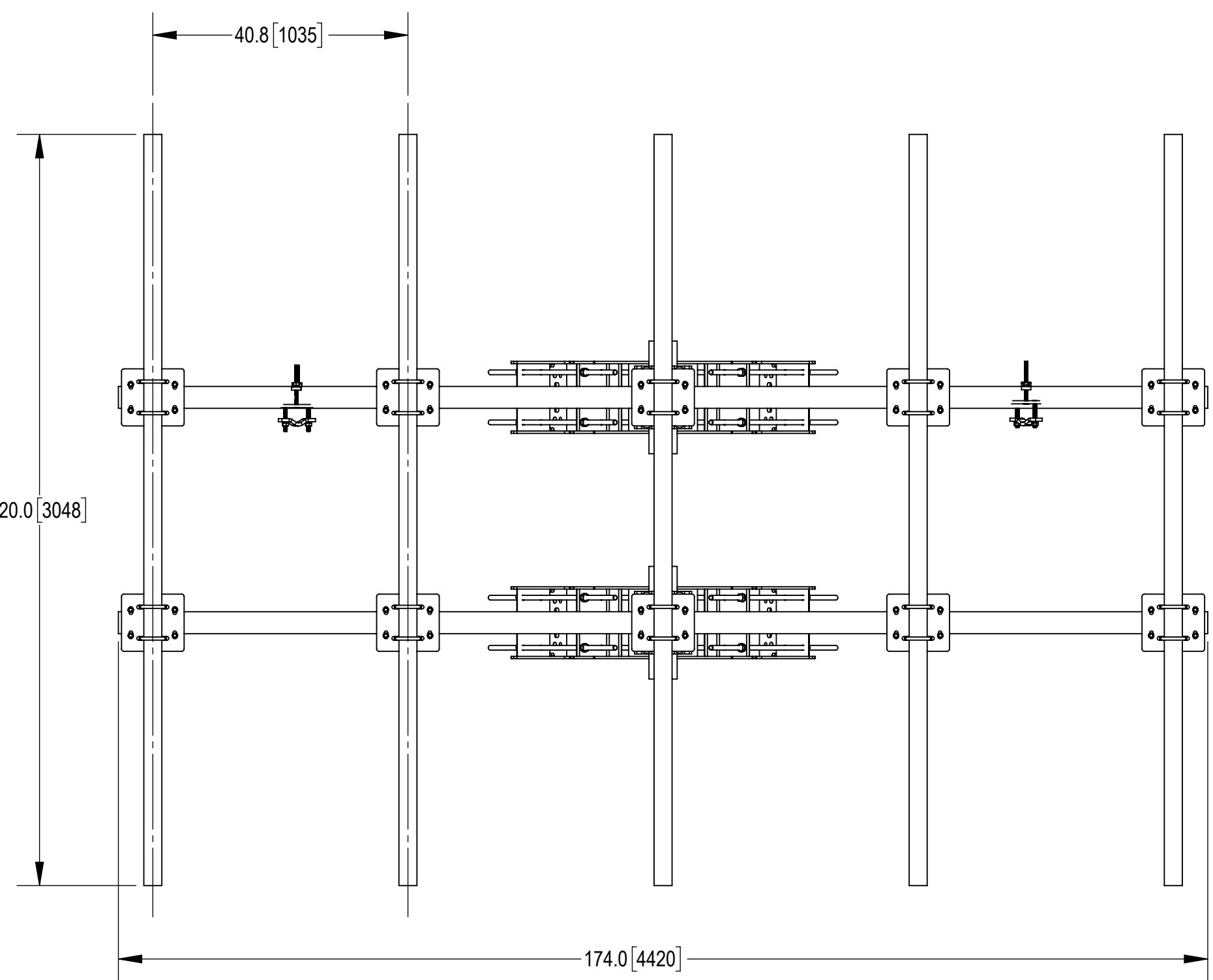

COMMSCOPE, INC. OF NORTH CAROLINA				
TITLE MONOPOLE, DBL T-ARM, 14' FACE, (15) 120" AP				
SIZE C	SCALE 1:20	DOCUMENT NO. MC-KD14M-15-WLL		
		DRAWING		SHEET
		VERSION	STATUS	REVISION
		01	RE	B
				SHEET 3 OF 3

© 2021 CommScope, Inc. Confidential

4

3

2

1