

TMAQ67LABC-11A | E14R00P38

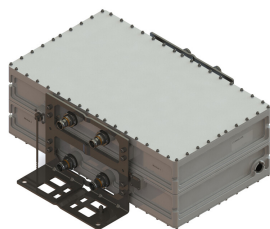

Quad-pack Tower Mounted Amplifier 600/700 MHz,4.3-10

- Variable gain, in steps of 1 dB
- New 4.3-10 connectors for improved PIM performance and size reduction

This product will be discontinued on: March 30, 2024

Product Classification

Product Type Tower mounted amplifier

General Specifications

Color Gray

Modularity 4-Quad

RF Connector Interface 4.3-10 Female

RF Connector Interface Body Style Long neck

Dimensions

Height 477 mm | 18.78 in

Width 275.5 mm | 10.846 in

Depth 163 mm | 6.417 in

TMAQ67LABC-11A | E14R00P38

Outline Drawing

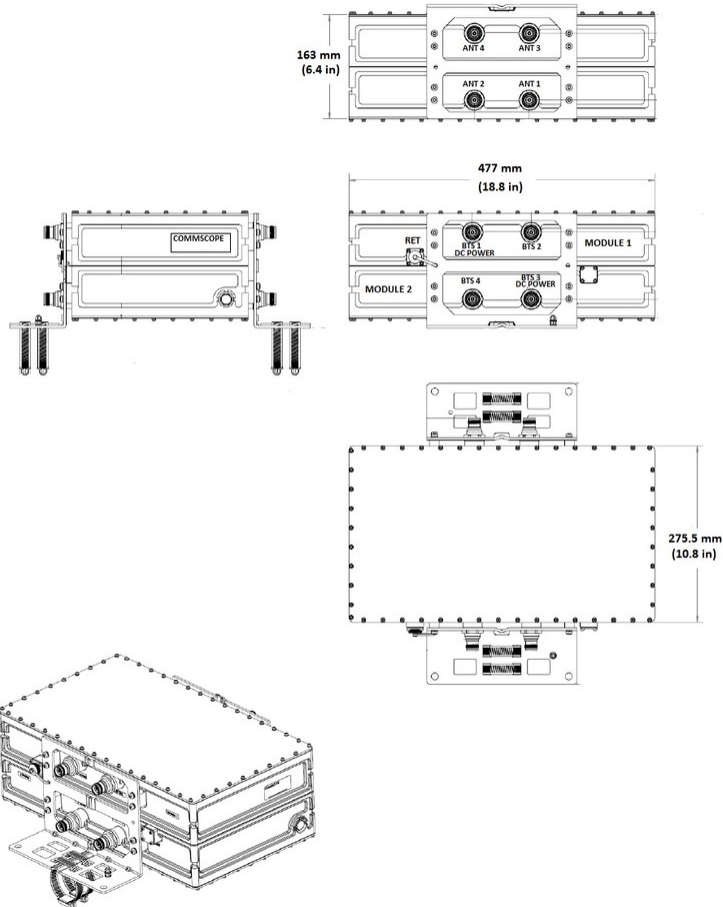

Electrical Specifications

License Band, LNA USA 700 | USA 750

Electrical Specifications, dc Power/Alarm

Lightning Surge Current 10 kA

Lightning Surge Current Waveform 8/20 waveform

Electrical Specifications, AISG

AISG Carrier 2.176 MHz \pm 100 ppm

AISG Connector 8-pin DIN Female

AISG Connector Standard IEC 60130-9

TMAQ67LABC-11A | E14R00P38

Protocol	AISG 2.0
Voltage, AISG Mode	10–30 Vdc

Electrical Specifications

Sub-module	1 2 3 4	1 2 3 4
Branch	1	1
AISG 2.0 Device Subunit	E14R00P38 1/3/5/7	E14R00P38 2/4/6/8
License Band		USA 700, LNA
Return Loss, typical, dB	22	22
Return Loss - Bypass Mode, typical, dB	16	16

Electrical Specifications Rx (Uplink)

Frequency Range, MHz	663–698	698–716
Gain, nominal, dB	13	13
Gain Tolerance, dB	±1.3	±1.3
Gain Adjustment Range, dB	5-13	5-13
Gain Adjustment Range Increments, dB	1	1
Noise Figure, typical, dB	1.2	1.2
Group Delay Variation, maximum, ns	8	8
Group Delay Variation Bandwidth, MHz	0.18	0.18
Total Group Delay, maximum, ns	250	250
Insertion Loss - Bypass Mode, typical, dB	2	2

Electrical Specifications Tx (Downlink)

Frequency Range, MHz	617–652	728–746
Insertion Loss, typical, dB	0.3	0.3
Total Group Delay, maximum, ns	70	70
Return Loss, typical, dB	22	22
Input Power, RMS, maximum, W	200	200
Input Power, PEP, maximum, W	2000	2000
3rd Order PIM, typical, dBc	-155	-155
3rd Order PIM Test Method	2 x 20 W CW tones	2 x 20 W CW tones

TMAQ67LABC-11A | E14R00P38

Block Diagram

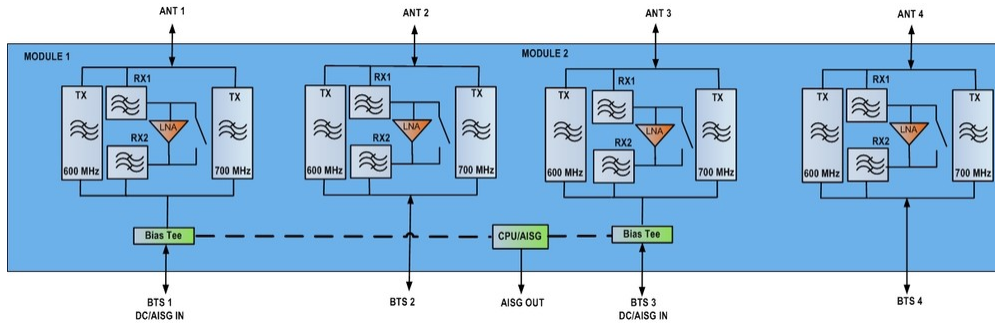

Material Specifications

Finish Painted

Environmental Specifications

Operating Temperature -40 °C to +65 °C (-40 °F to +149 °F)

Relative Humidity Up to 100%

Corrosion Test Method IEC 60068-2-11, 30 days

Ingress Protection Test Method IEC 60529:2001, IP67

Packaging and Weights

Mounting Hardware Weight 2 kg | 4.409 lb

Weight, without mounting hardware 23.8 kg | 52.47 lb

* Footnotes

License Band, LNA License Bands that have RxUplink amplification