

400PUM



UHF Male for CNT-400 braided cable

Product Classification

Product Type	Braided cable connector
Product Brand	CNT®

General Specifications

Body Style	Straight
Inner Contact Attachment Method	Solder
Inner Contact Plating	Silver
Interface	UHF Male
Outer Contact Attachment Method	Clamp
Outer Contact Plating	Trimetal
Pressurizable	No

Dimensions

Width	22.35 mm 0.88 in
Length	46.1 mm 1.815 in
Diameter	22.35 mm 0.88 in
Nominal Size	0.405 in

Outline Drawing

400PUM

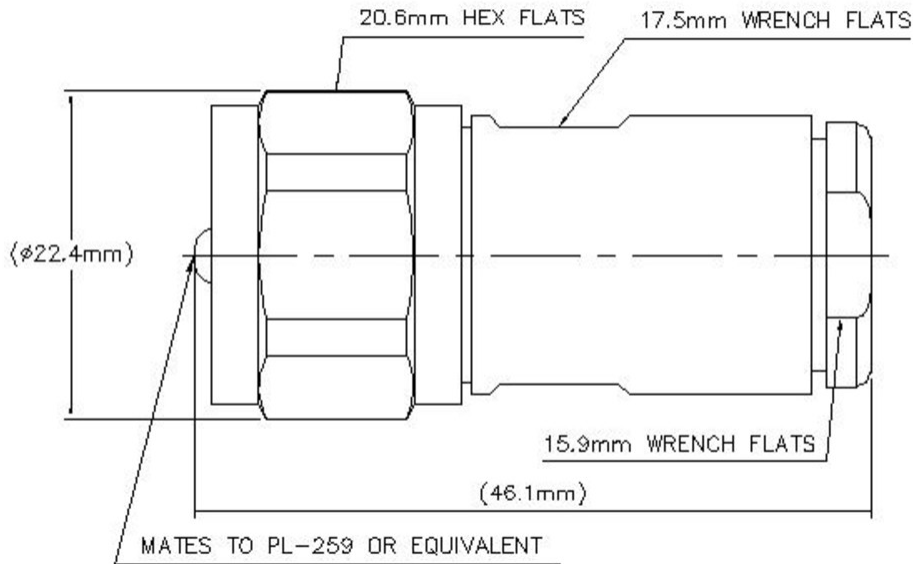

Electrical Specifications

Insertion Loss, typical	0.05 dB
Average Power at Frequency	580.0 W @ 900 MHz
Cable Impedance	50 ohm
Connector Impedance	50 ohm
dc Test Voltage	1500 V
Inner Contact Resistance, maximum	6 mOhm
Insulation Resistance, minimum	5000 MOhm
Operating Frequency Band	0 – 1000 MHz
Outer Contact Resistance, maximum	9 mOhm
RF Operating Voltage, maximum (vrms)	500 V

VSWR/Return Loss

Frequency Band	VSWR	Return Loss (dB)
0–300 MHz	1.433	14.99
300–600 MHz	1.433	14.99
600–1000 MHz	1.671	12

Mechanical Specifications

Connector Retention Tensile Force	330 N 74.187 lbf
--	--------------------

400PUM

Connector Retention Torque	0.56 N-m 4.956 in lb 0.75 N-m 6.638 in lb
Coupling Nut Proof Torque	1.7 N-m 15.046 in lb
Interface Durability	500 cycles
Interface Durability Method	IEC 61169-12:9.5
Mechanical Shock Test Method	IEC 60068-2-27

Environmental Specifications

Operating Temperature	-40 °C to +85 °C (-40 °F to +185 °F)
Storage Temperature	-65 °C to +125 °C (-85 °F to +257 °F)
Attenuation, Ambient Temperature	20 °C 68 °F
Average Power, Ambient Temperature	40 °C 104 °F
Average Power, Inner Conductor Temperature	100 °C 212 °F
Climatic Sequence Test Method	IEC 60068-1
Corrosion Test Method	IEC 60068-2-11
Damp Heat Steady State Test Method	IEC 60068-2-3
Immersion Depth	1 m
Immersion Test Mating	Mated
Immersion Test Method	IEC 60529:2001, IP68
Thermal Shock Test Method	IEC 60068-2-14
Vibration Test Method	IEC 60068-2-6

Packaging and Weights

Weight, net	73 g 0.161 lb
--------------------	-----------------

Regulatory Compliance/Certifications

Agency	Classification
CHINA-ROHS	Below maximum concentration value
ISO 9001:2015	Designed, manufactured and/or distributed under this quality management system
REACH-SVHC	Compliant as per SVHC revision on www.commscope.com/ProductCompliance
ROHS	Compliant



* Footnotes

400PUM

Insertion Loss, typical 0.05v⁻¹freq (GHz) (not applicable for elliptical waveguide)

Immersion Depth Immersion at specified depth for 24 hours