

400NM-P



Type N Male for CNT-400 braided cable

OBSOLETE

This product was discontinued on: August 11, 2018

Product Classification

Product Type	Braided cable connector
Product Brand	CNT® ConQuest®

General Specifications

Body Style	Straight
Inner Contact Attachment Method	Captivated
Inner Contact Plating	Silver
Interface	N Male
Outer Contact Attachment Method	Crimp
Outer Contact Plating	Trimetal

Dimensions

Width	20 mm 0.787 in
Length	40.6 mm 1.598 in
Diameter	20 mm 0.787 in
Nominal Size	0.405 in

Outline Drawing

400NM-P

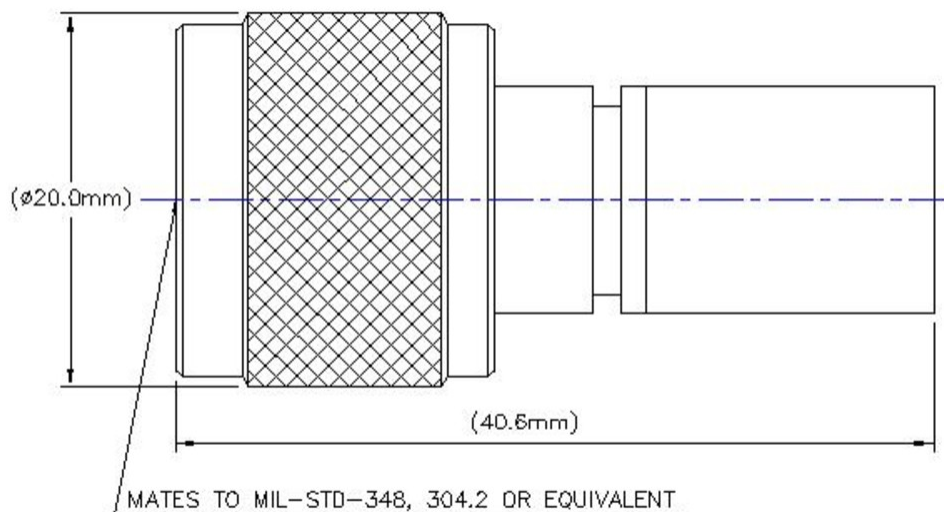

Electrical Specifications

Insertion Loss, typical	0.05 dB
Cable Impedance	50 ohm
Connector Impedance	50 ohm
dc Test Voltage	2500 V
Inner Contact Resistance, maximum	1 mOhm
Insulation Resistance, minimum	5000 MOhm
Operating Frequency Band	0 – 6000 MHz
Outer Contact Resistance, maximum	0.25 mOhm
Peak Power, maximum	10 kW
RF Operating Voltage, maximum (vrms)	707 V

VSWR/Return Loss

Frequency Band	VSWR	Return Loss (dB)
0–3000 MHz	1.12	25
3000–6000 MHz	1.44	15

Mechanical Specifications

Connector Retention Tensile Force	330 N 74.187 lbf
Connector Retention Torque	0.56 N-m 4.956 in lb

400NM-P

Coupling Nut Proof Torque	1.7 N-m 15.046 in lb
Coupling Nut Proof Torque Method	IEC 61169-16:9.3.6
Coupling Nut Retention Force	450 N 101.164 lbf
Coupling Nut Retention Force Method	IEC 61169-16:9.3.11
Interface Durability	500 cycles
Interface Durability Method	IEC 61169-16:9.5
Mechanical Shock Test Method	IEC 60068-2-27

Environmental Specifications

Operating Temperature	-40 °C to +85 °C (-40 °F to +185 °F)
Storage Temperature	-65 °C to +125 °C (-85 °F to +257 °F)
Attenuation, Ambient Temperature	20 °C 68 °F
Average Power, Ambient Temperature	40 °C 104 °F
Average Power, Inner Conductor Temperature	100 °C 212 °F
Climatic Sequence Test Method	IEC 60068-1
Corrosion Test Method	IEC 60068-2-11
Damp Heat Steady State Test Method	IEC 60068-2-3
Thermal Shock Test Method	IEC 60068-2-14
Vibration Test Method	IEC 60068-2-6
Water Jetting Test Mating	Mated
Water Jetting Test Method	IEC 60529:2001, IP65

Packaging and Weights

Weight, net	29.9 g 0.066 lb
--------------------	-------------------

Regulatory Compliance/Certifications

Agency	Classification
ISO 9001:2015	Designed, manufactured and/or distributed under this quality management system



* Footnotes

Insertion Loss, typical	0.05v~freq (GHz) (not applicable for elliptical waveguide)
--------------------------------	------------------------------------------------------------