

4

3

2

1

NOTES:
1.0 ALL METRIC DIMENSIONS ARE IN BRACKETS.

REVISIONS				
REV.	ECN	DESCRIPTION	BY	DATE
A	800009677	INITIAL RELEASE	RJC	08/10/15

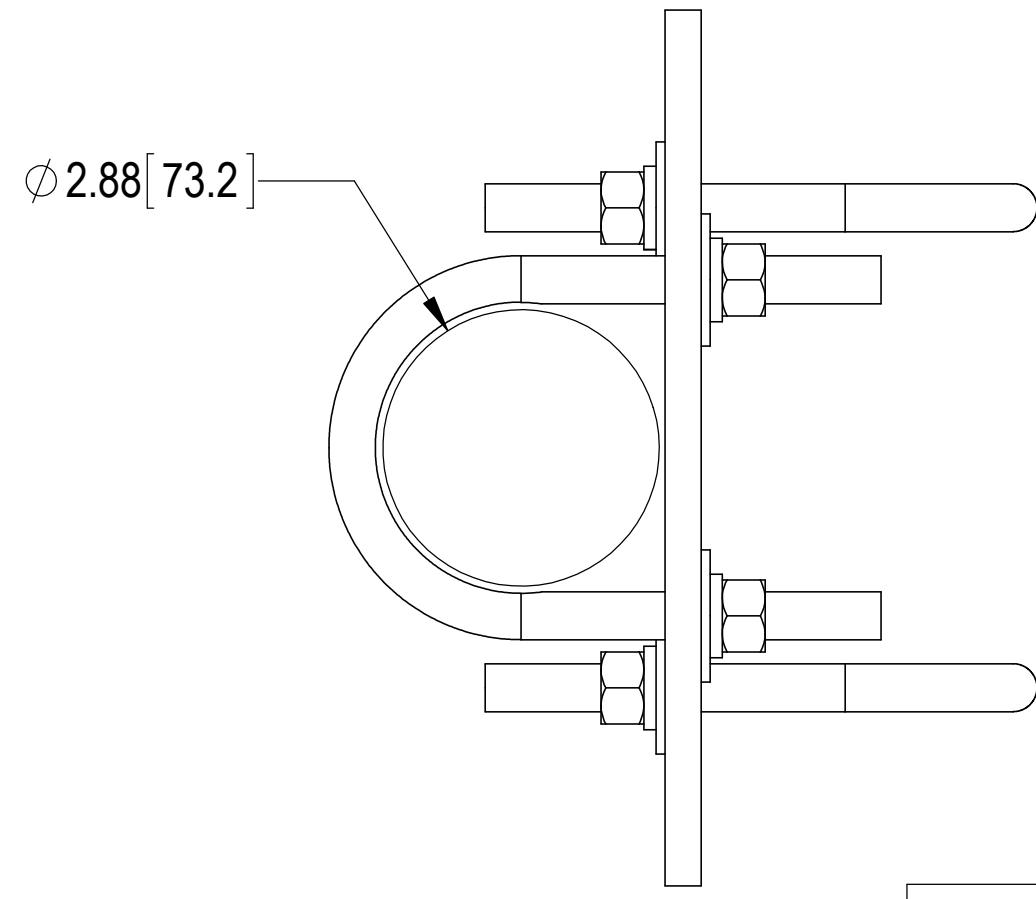
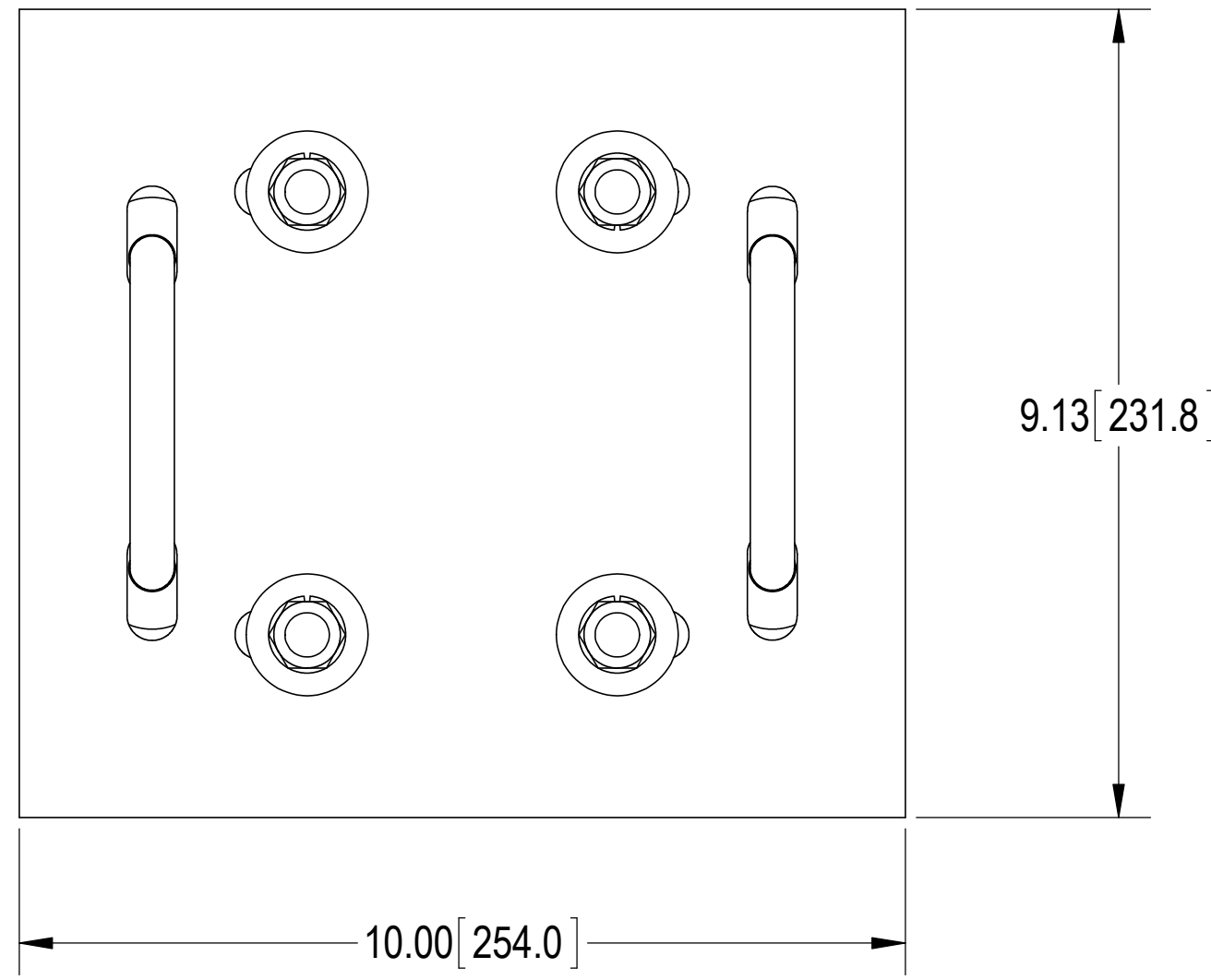
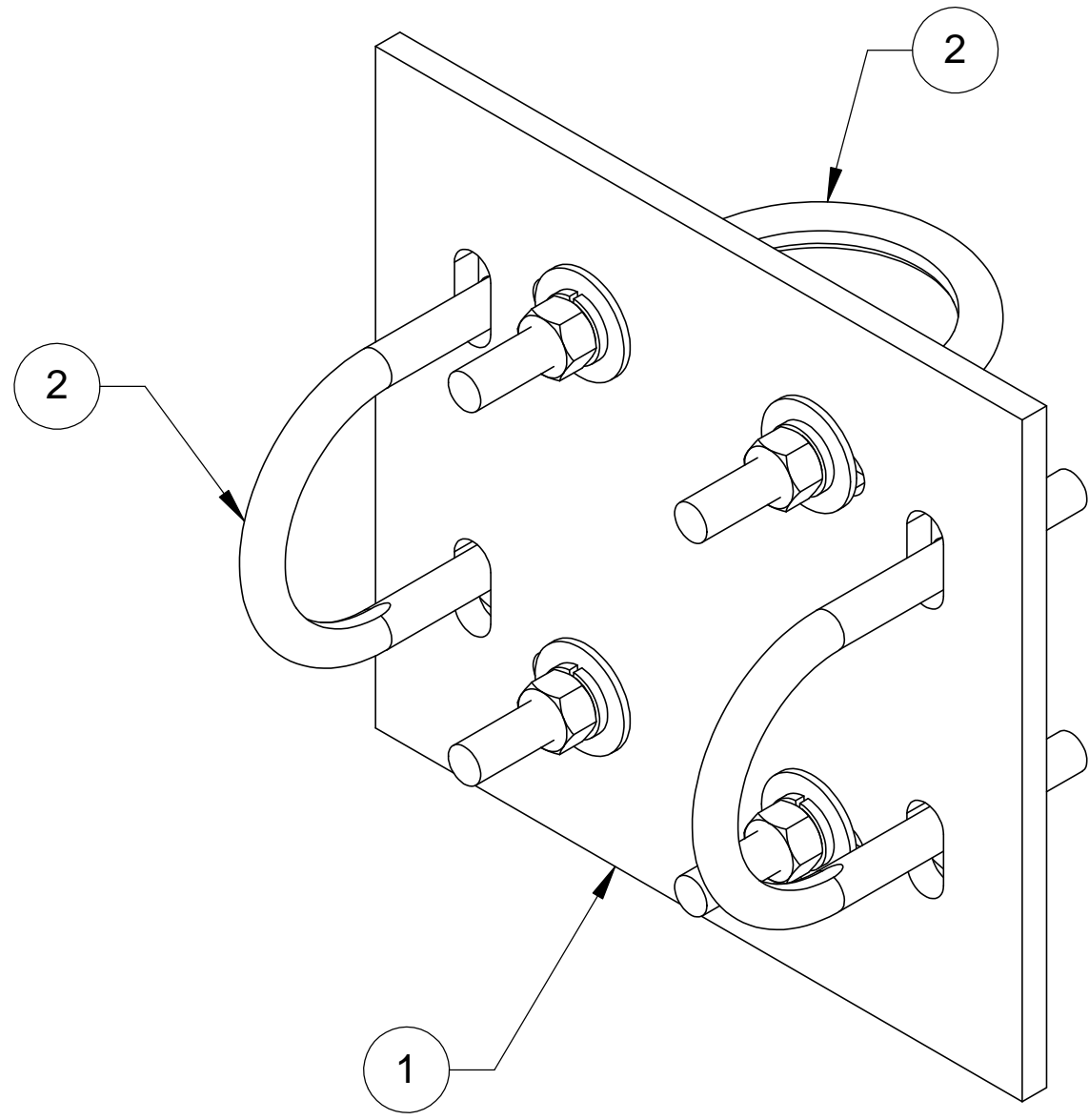
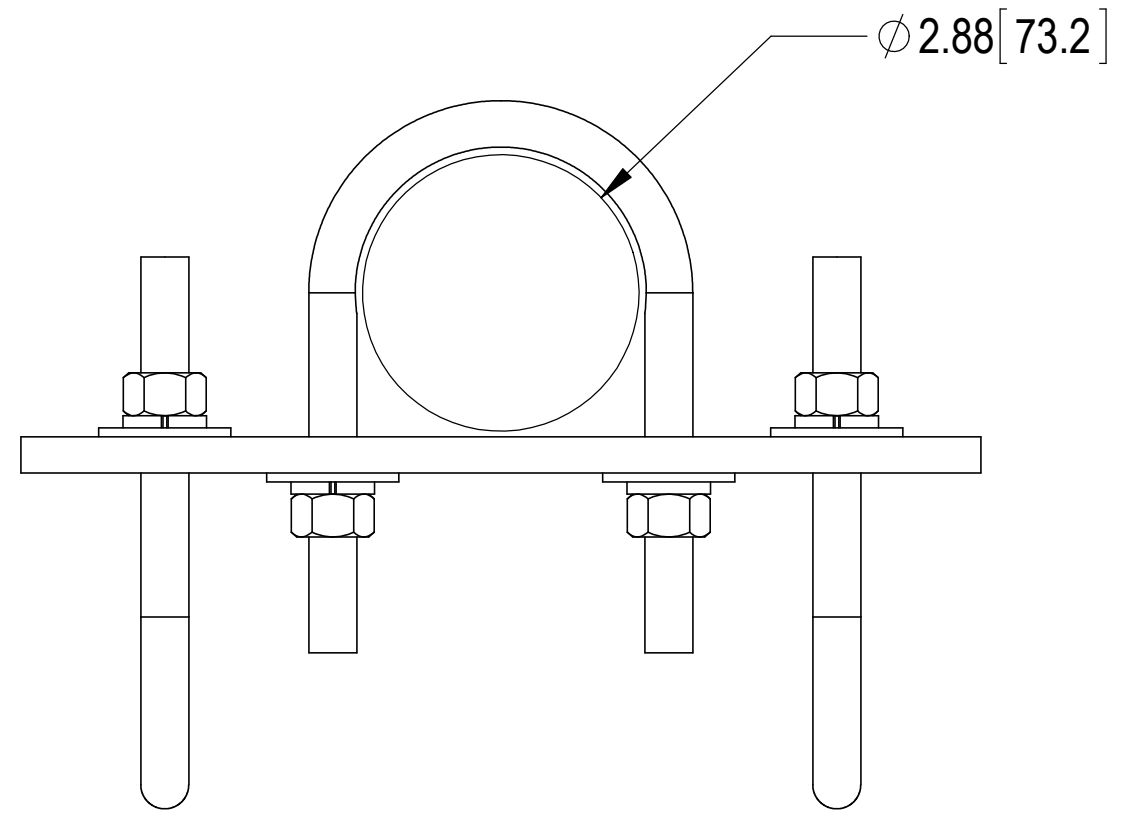

ITEM	PART NO.	DESCRIPTION	QTY.	WEIGHT	NOTE NO.
1	XP3030.01	CROSSOVER PLATE Ø 3-1/2" O.D. TO Ø 3-1/2" O.D.	1	9.11 LBS	
2	GUB-4352	1/2" X 3" X 5-1/4" GALV U-BOLT	4	0.72 LBS	

COMMSCOPE, INC. OF NORTH CAROLINA

TOLERANCES		SAP MATERIAL MASTER	
0 PLACE X ± .25	2 PLACE .XX ± .06	XP-2525	
1 PLACE .X ± .12	ANGLES ± 2°		
FINISH		MATERIAL	
GALV A123		A36	
UNLESS OTHERWISE SPECIFIED DIMENSIONS ARE IN MILLIMETERS INTERPRET PER ISO STANDARDS HANDBOOK TECHNICAL DRAWINGS VOLUMES 1 & 2, THIRD EDITION (2002)	CE	NAME	DATE
	RW	RJC	08/10/15
	RV		
	AD		
	RE	TP	08/10/15
ECN	8000009677		TITLE
		SCALE	DOCUMENT NO.
		1:2	XP-2525
SIZE	WORK AREA	MODEL	
C		VERSION	DRAWING
		STATUS	REVISION
		REVISION	VERSION
		STATUS	REVISION
			A
			SHEET
			1 OF 1