

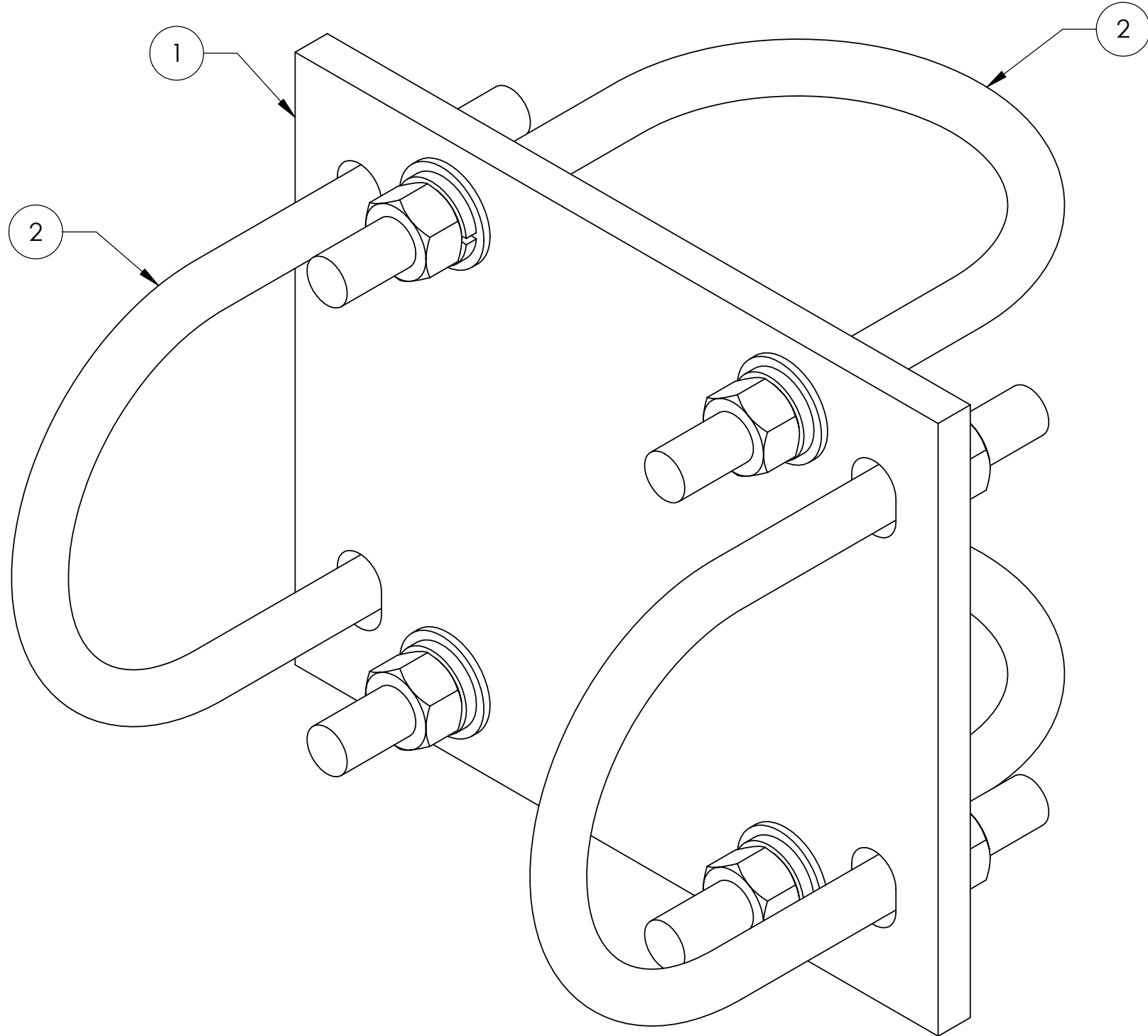

ITEM	PART NO.	DESCRIPTION	QTY.	WEIGHT
1	XP4040.01	CROSSOVER PLATE ϕ 4.5" O.D. TO ϕ 4.5" O.D.	1	10.96 LBS
2	GUB-5456	5/8" X 4-5/8" X 6-1/2" GALV U-BOLT	4	1.54 LBS

REVISIONS				
REV.	ZONE	DESCRIPTION	BY	DATE
A		INITIAL RELEASE	MA	04/19/01



<p>These drawings and specifications are the proprietary property of ANDREW CORPORATION and may be used only for the specific purpose authorized in writing by Andrew Corporation.</p> <p>ALL DIMENSIONS ARE IN INCHES U.O.S. TOLERANCES UNLESS OTHERWISE SPECIFIED: .X = \pm .06 ANGLES \pm 2° .XX = \pm .03 FRACTIONS \pm 1/32 .XXX = \pm .010</p> <p>REMOVE BURRS AND BREAK EDGES .005</p> <p>DO NOT SCALE THIS PRINT</p>	DRAWN BY: ACG	SHEET: 1 of 1	PART NUMBER: XP-4040
	CHECKED BY: TP	SCALE: NTS	DESCRIPTION: CROSSOVER PLATE ϕ 4.5" O.D. TO ϕ 4.5" O.D.
	DATE: 02/23/06	MATERIAL: A36	DRAWING TYPE: ASSEMBLY DRAWING
	REVISION: A	FINISH: GALV A123	
	WEIGHT: 18.20 LBS	ORLAND PARK, IL. 60462 U.S.A.	