

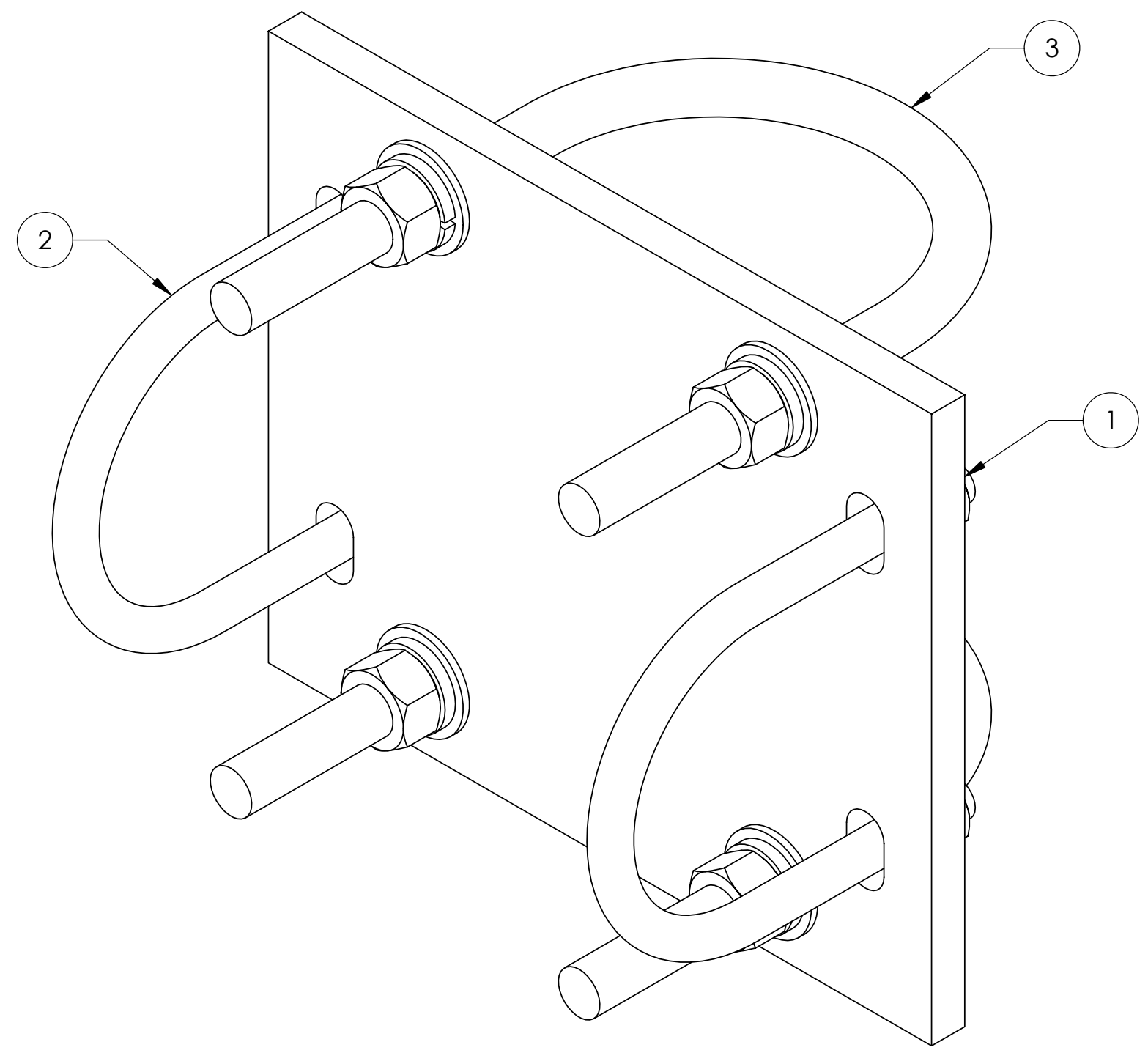

ITEM	PART NO.	DESCRIPTION	QTY.	WEIGHT
1	XP3040.01	CROSSOVER PLATE $\phi$ 3.5" O.D. TO $\phi$ 4.5" O.D.	1	11.01 LBS
2	GUB-4355	1/2" X 3-5/8" X 5" GALV U-BOLT KIT	2	0.72 LBS
3	GUB-5456	5/8" X 4-5/8" X 6-1/2" GALV U-BOLT	2	1.54 LBS

REVISIONS				
REV.	ZONE	DESCRIPTION	BY	DATE
A		INITIAL RELEASE	WLJ	03/12/99
B		REDRAWN AND REVISED	MA	04/19/01



<p>These drawings and specifications are the proprietary property of ANDREW CORPORATION and may be used only for the specific purpose authorized in writing by Andrew Corporation.</p> <p>ALL DIMENSIONS ARE IN INCHES U.O.S. TOLERANCES UNLESS OTHERWISE SPECIFIED: .X = <math>\pm</math> .06      ANGLES <math>\pm</math> 2° .XX = <math>\pm</math> .03      FRACTIONS <math>\pm</math> 1/32 .XXX = <math>\pm</math> .010</p> <p>REMOVE BURRS AND BREAK EDGES .005</p> <p>DO NOT SCALE THIS PRINT</p>	DRAWN BY: ACG	SHEET: 1 of 1	PART NUMBER: XP-3040
	CHECKED BY: TP	SCALE: NTS	DESCRIPTION: CROSSOVER PLATE $\phi$ 3.5" O.D. TO $\phi$ 4.5" O.D.
	DATE: 02/23/06	MATERIAL: A36	DRAWING TYPE: ASSEMBLY DRAWING
	REVISION: B	FINISH: GALV A123	 ORLAND PARK, IL. 60462 U.S.A.
		WEIGHT: 16.37 LBS	