

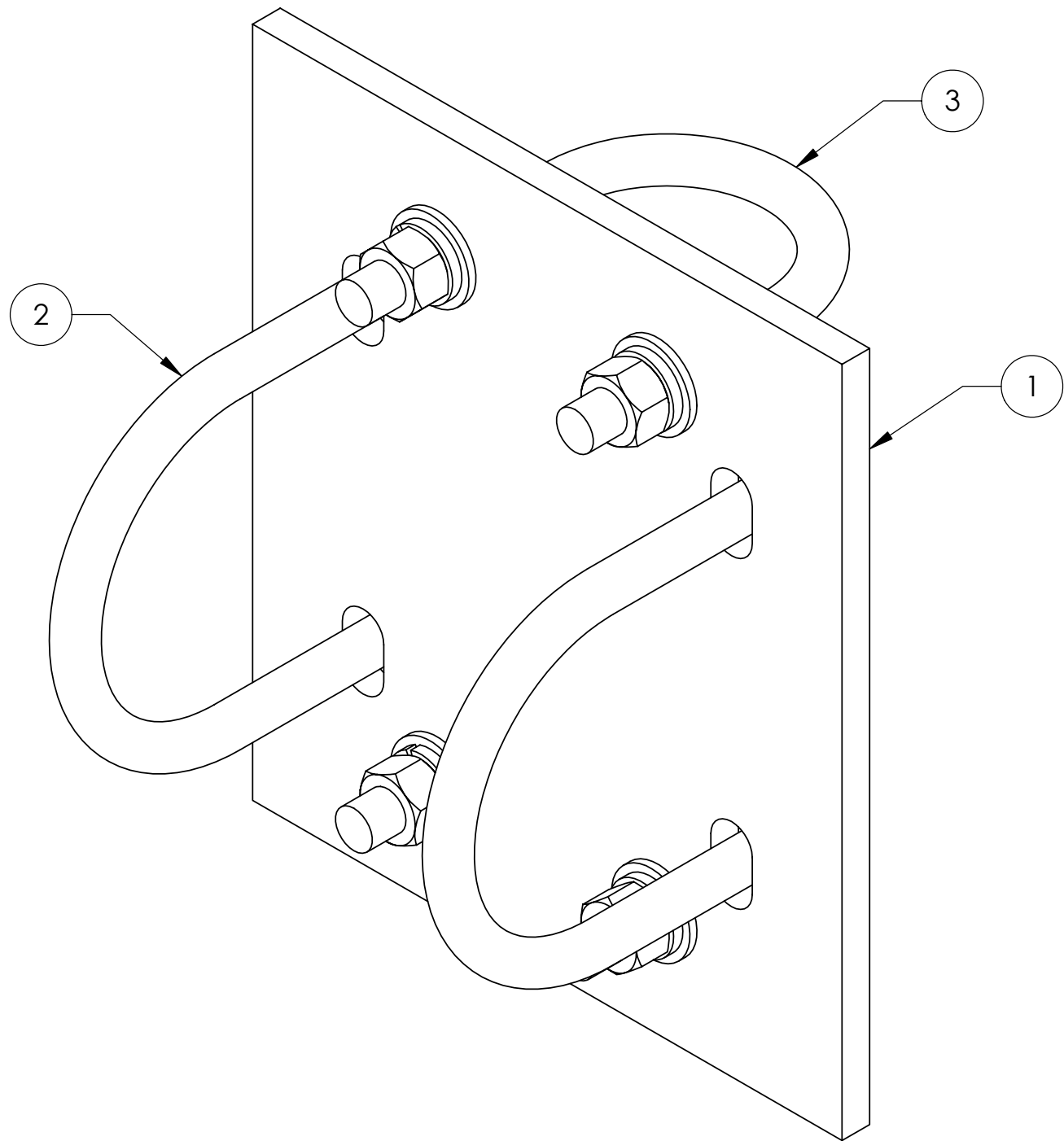

ITEM	PART NO.	DESCRIPTION	QTY.	WEIGHT
1	XP2030.01	CROSSOVER PLATE ϕ 2-3/8" O.D. TO ϕ 3-1/2" O.D.	1	7.30 LBS
2	GUB-4355	1/2" X 3-5/8" X 5" GALV U-BOLT KIT	2	0.72 LBS
3	GUB-4240	1/2" X 2-1/2" X 4" GALV U-BOLT KIT	2	0.57 LBS

REVISIONS				
REV.	ZONE	DESCRIPTION	BY	DATE
A		INITIAL RELEASE	TDM	01/07/00
B		CORRECT TYPO	TDM	01/10/00
C		ADDED BOM	MA	04/19/01
D		REMOVED 1 VIEW	JTS	06/07/01



<p>These drawings and specifications are the proprietary property of ANDREW CORPORATION and may be used only for the specific purpose authorized in writing by Andrew Corporation.</p> <p>ALL DIMENSIONS ARE IN INCHES U.O.S. TOLERANCES UNLESS OTHERWISE SPECIFIED: .X = \pm .06 ANGLES \pm 2° .XX = \pm .03 FRACTIONS \pm 1/32 .XXX = \pm .010</p> <p>REMOVE BURRS AND BREAK EDGES .005</p> <p>DO NOT SCALE THIS PRINT</p>	DRAWN BY: ACG	SHEET: 1 of 1	PART NUMBER: XP-2030
	CHECKED BY: TP	SCALE: NTS	DESCRIPTION: CROSSOVER PLATE ϕ 2.375" O.D. TO ϕ 3.5" O.D.
	DATE: 01/26/05	MATERIAL: A36	DRAWING TYPE: ASSEMBLY DRAWING
	REVISION: D	FINISH: GALV A123	
	WEIGHT: 10.46 LBS	ORLAND PARK, IL. 60462 U.S.A.	