

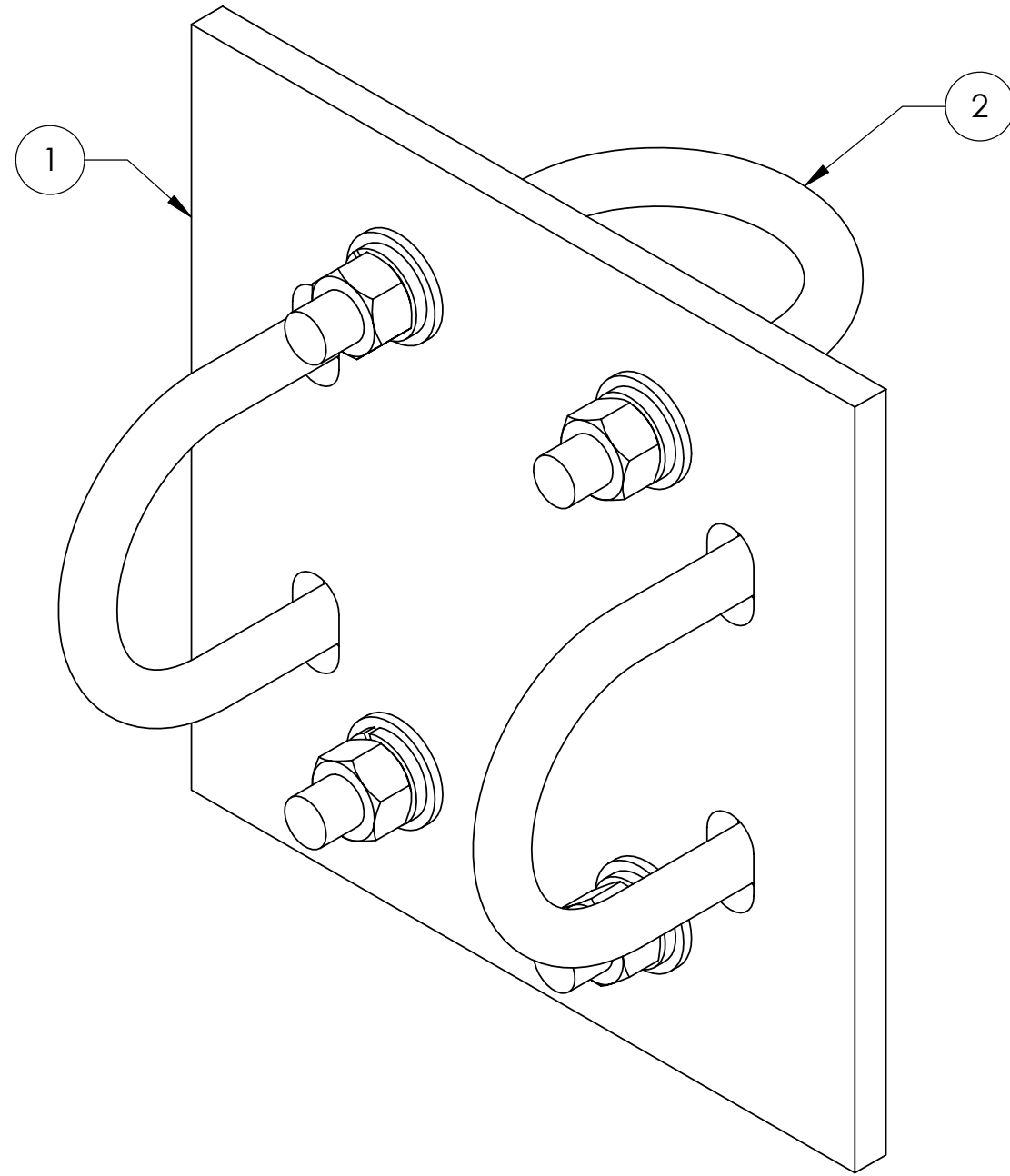

ITEM	PART NO.	DESCRIPTION	QTY.	WEIGHT
1	XP2020.01	CROSSOVER PLATE 2-3/8" O.D. TO 2-3/8" O.D.	1	6.34 LBS
2	GUB-4240	1/2" X 2-1/2" X 4" GALV U-BOLT KIT	4	0.57 LBS

REVISIONS				
REV.	ZONE	DESCRIPTION	BY	DATE
A		INITIAL RELEASE	MLO	05/24/99
B		REDRAWN AND ADDED BOM	MA	04/19/01
C		REMOVED 1 VIEW	JTS	06/07/01



<p>These drawings and specifications are the proprietary property of ANDREW CORPORATION and may be used only for the specific purpose authorized in writing by Andrew Corporation.</p> <p>ALL DIMENSIONS ARE IN INCHES U.O.S. TOLERANCES UNLESS OTHERWISE SPECIFIED:</p> <p>.X = ± .06      ANGLES      ±2° .XX = ± .03      FRACTIONS      ±1/32 .XXX = ± .010</p> <p>REMOVE BURRS AND BREAK EDGES .005</p> <p>DO NOT SCALE THIS PRINT</p>	DRAWN BY ACG	SHEET 1 of 1	PART NUMBER XP-2020
	CHECKED BY TP	SCALE NTS	DESCRIPTION CROSSOVER PLATE KIT 2.375" O.D. X 2.375" O.D.
	DATE 01/07/05	MATERIAL A36	DRAWING TYPE ASSEMBLY DRAWING
	REVISION: <b>C</b>	FINISH GALV A123	
	WEIGHT 9.22 LBS	ORLAND PARK, IL. 60462 U.S.A.	