

ITEM	PART NO.	DESCRIPTION	QTY.	WEIGHT
1	WRTA.32	PIPE (SEE TABLE 1)		37.10 LBS
2	WRTA.19	WELDED FOOT	3	18.23 LBS
3	WRTA.27	LONG TOE BOARD SECTION	6	3.80 LBS
4	WRTA.26	ANGLE, 6'	4	27.88 LBS
5	WRTA.25	KICKER ANGLE	3	19.85 LBS
6	WRTA.20	REAR FOOT	3	16.30 LBS
7	WTSMAH	HARDWARE KIT (ITEMS 8-13)	1	
8	WRTA.21	WELDED BRACKET	6	7.11 LBS
9	GUB-4240	1/2" X 2-1/2" X 4" GALV U-BOLT KIT	10	0.56 LBS
10	GB-05445	5/8" X 4-1/2" GALV BOLT KIT	3	0.48 LBS
11	GB-05145	5/8" X 1-1/2" GALV BOLT KIT	14	0.22 LBS
12	GB-04145	1/2" X 1-1/2" GALV BOLT KIT	9	0.22 LBS
13	GW-04	1/2" GALV FLAT WASHER	18	0.02 LBS

REVISIONS				
REV.	ZONE	DESCRIPTION	BY	DATE
D		NEW DESIGN	AW	03/31/05

ASSEMBLY #	PART #	QTY.	WEIGHT
WT-SMA12-3-96	WTRTA.32	3	467.60 LBS
WT-SMA12-4-96	WTRTA.32	5	541.80 LBS

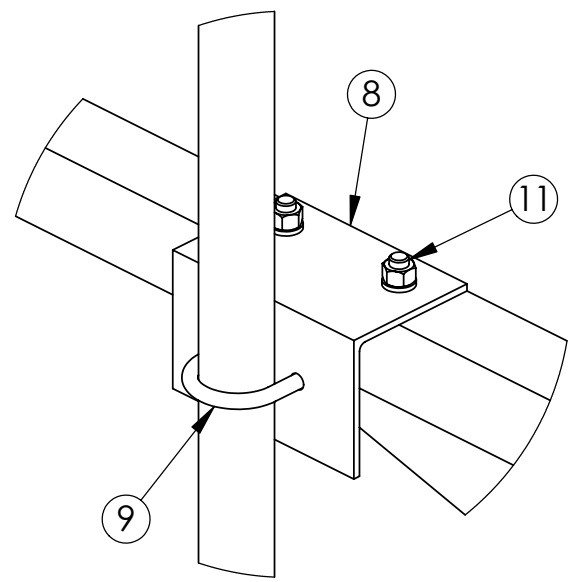

DETAIL A

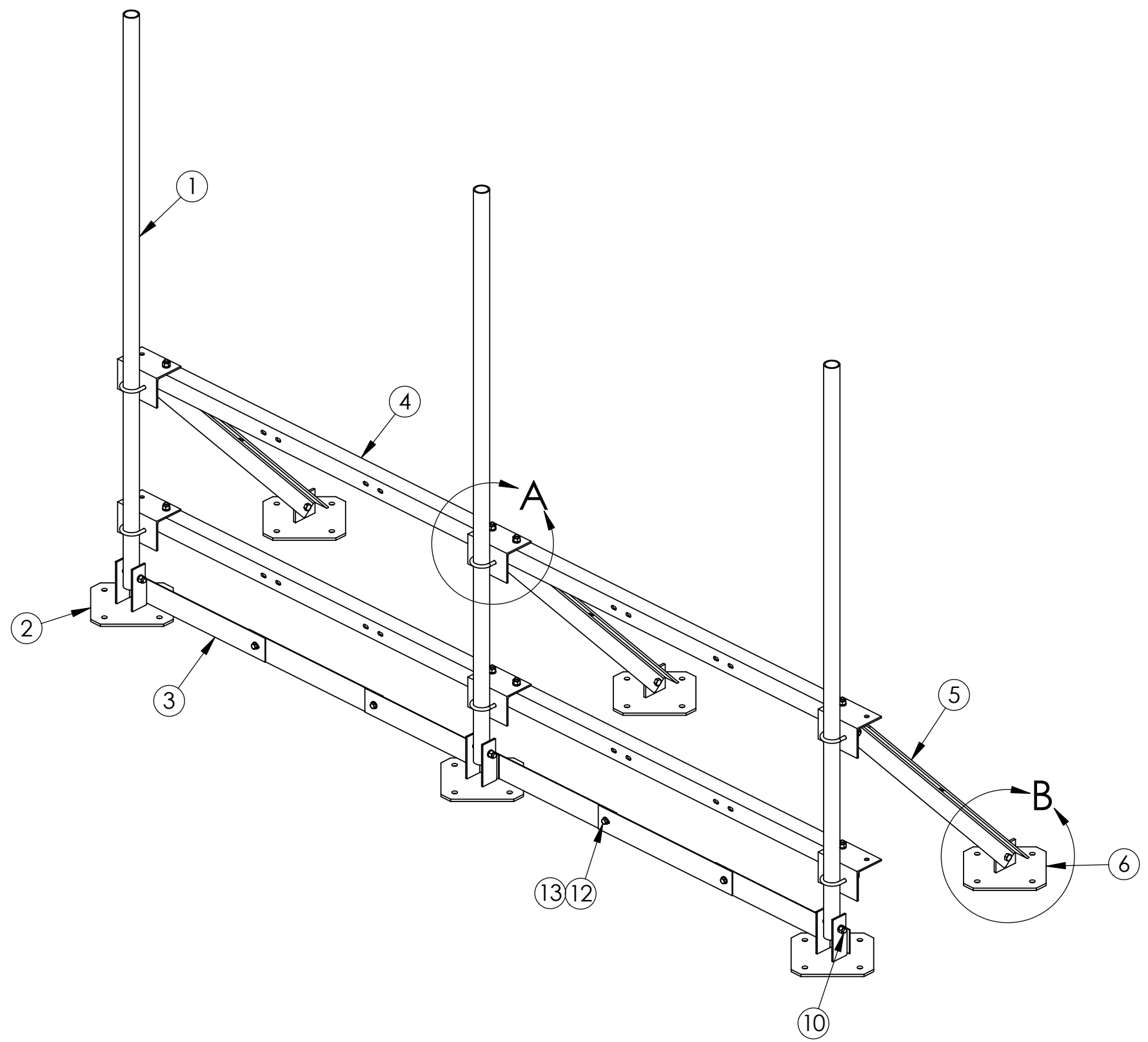

These drawings and specifications are the proprietary property of ANDREW CORPORATION and may be used only for the specific purpose authorized in writing by Andrew Corporation.  ALL DIMENSIONS ARE IN INCHES U.O.S. TOLERANCES UNLESS OTHERWISE SPECIFIED: .X = ± .06      ANGLES ± 2° .XX = ± .03      FRACTIONS ± 1/32 .XXX = ± .010  REMOVE BURRS AND BREAK EDGES .005  DO NOT SCALE THIS PRINT	DRAWN BY: AW	SHEET: 1 of 1	PART NUMBER: WT-SMA12 SERIES
	CHECKED BY: TP	SCALE: NTS	DESCRIPTION: 12' WATER TOWER ROOF TOP SECTOR FRAME
	DATE: 03/31/05	MATERIAL: A36, A53	DRAWING TYPE: ASSEMBLY DRAWING
	REVISION: D	FINISH: GALV A123	 ORLAND PARK, IL. 60462 U.S.A.
	WEIGHT: SEE TABLE1		