

4

3

2

1

NOTES:

REVISIONS			
REV	DESCRIPTION	DATE	APPROVED
A	ECR 5102367: RELEASE TO PRODUCTION PER EAO 4007373.	18FEB11 K.W	R.SU/WSY
C	ECR 8000005043: UPDATE DRAWING.	10SEP14 YR	XA.FU/QIULI
D	ECR 8000010960: UPDATE DRAWING WITH THE LATEST MODEL.	10NOV15 HWW	HV/XA
E	ECR 8000011783: UPDATE DRAWING WITH THE LATEST MODEL.	07JAN16 SXH	S.LIU/JIHE
F	ECR 8000027967: UPDATE DRAWING WITH THE LATEST MODEL.	18JAN18 CN	S.LIU/JIHE

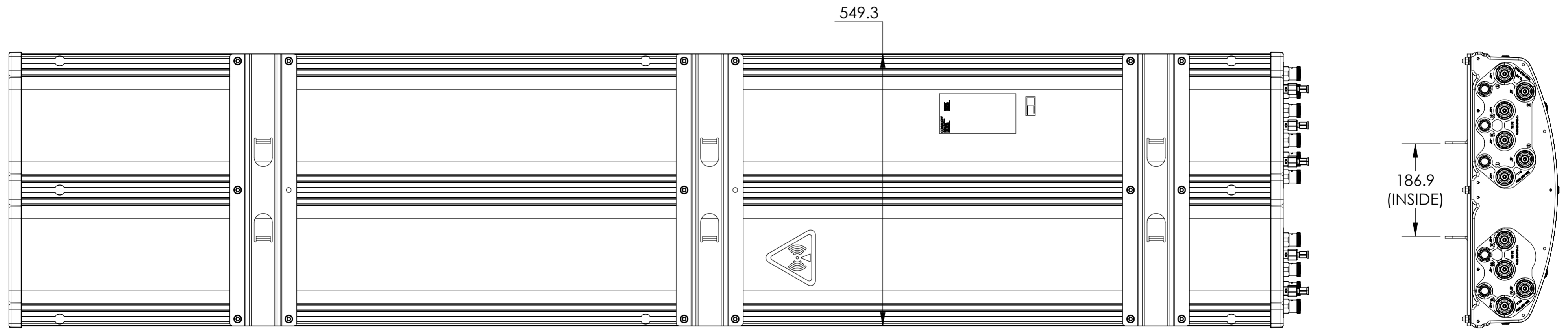
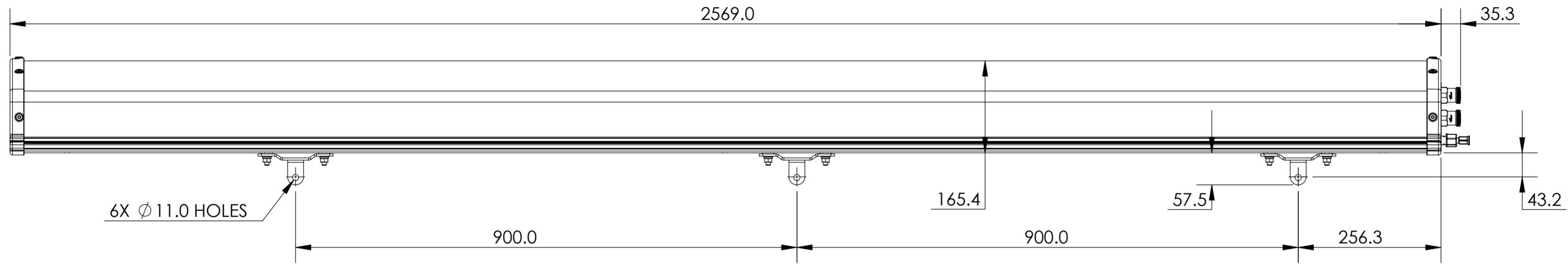

MBLLHHH-65C-VTM

MATERIAL N/A	DENSITY:	UNLESS OTHERWISE SPECIFIED DIMENSIONS ARE IN MILLIMETERS INTERPRET PER ISO STANDARDS HANDBOOK TECHNICAL DRAWINGS VOLUMES 1 & 2, THIRD EDITION (2002)	WESTCHESTER, IL. 60154 U.S.A.	
	MASS:			
FINISH N/A	TOLERANCES		THIRD ANGLE PROJECTION	
	0 PLACE X ± 1 PLACE .X ± 2 PLACE .XX ± ANGLES ±			
ALL SURFACES ✓		AUTH. GROUP 23 DRAWN BY K.W 18FEB11 ECN 8000027967-0	SIZE A2 CAGE CODE 84147	DOCUMENT NO. MBLLHHH-65C-VTM-L
NOTICE: These drawings and specifications are the proprietary property of ANDREW CORPORATION and may be used only for the specific purpose authorized in writing by Andrew.		MODEL VERSION 05 STATUS RE REVISION E	DRAWING VERSION 06 STATUS RE REVISION F	SHEET 1 OF 2

4

3

2

1

THIRD ANGLE PROJECTION

4

3

2

1

D

D

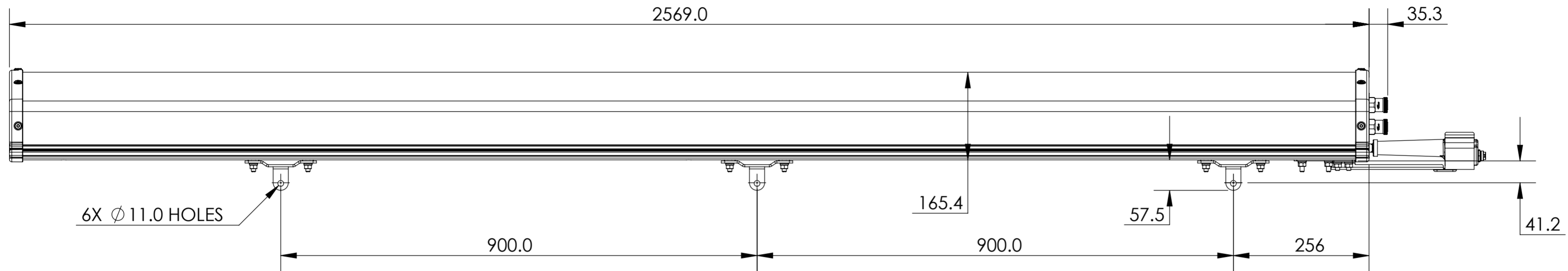

C

C

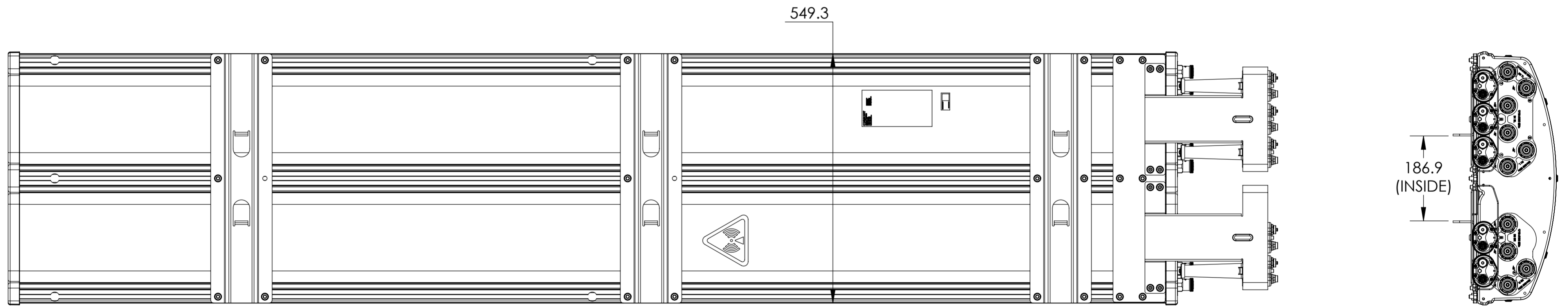

MBLLHHH-65C-R2M
 MBLLHHH-65C-A5M

A

A

ANDREW WESTCHESTER, IL. 60154
 U.S.A.

PRODUCT DRAWING

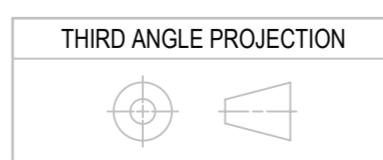

SIZE	CAGE CODE	DOCUMENT NO.
A2	84147	MBLLHHH-65C-VTM-L

VERSION	STATUS	REVISION	SHEET
06	RE	F	2 OF 2

NOTICE: These drawings and specifications are the proprietary property of ANDREW CORPORATION and may be used only for the specific purpose authorized in writing by Andrew.

4

3

2

1

THIRD ANGLE PROJECTION