

REVISIONS			
REV.	DESCRIPTION	DATE	APPROVED
A	ECR 8000037919: REL TO PRODUCTION PER EAO 607404.	04NOV19 Q.W	CC/ZT

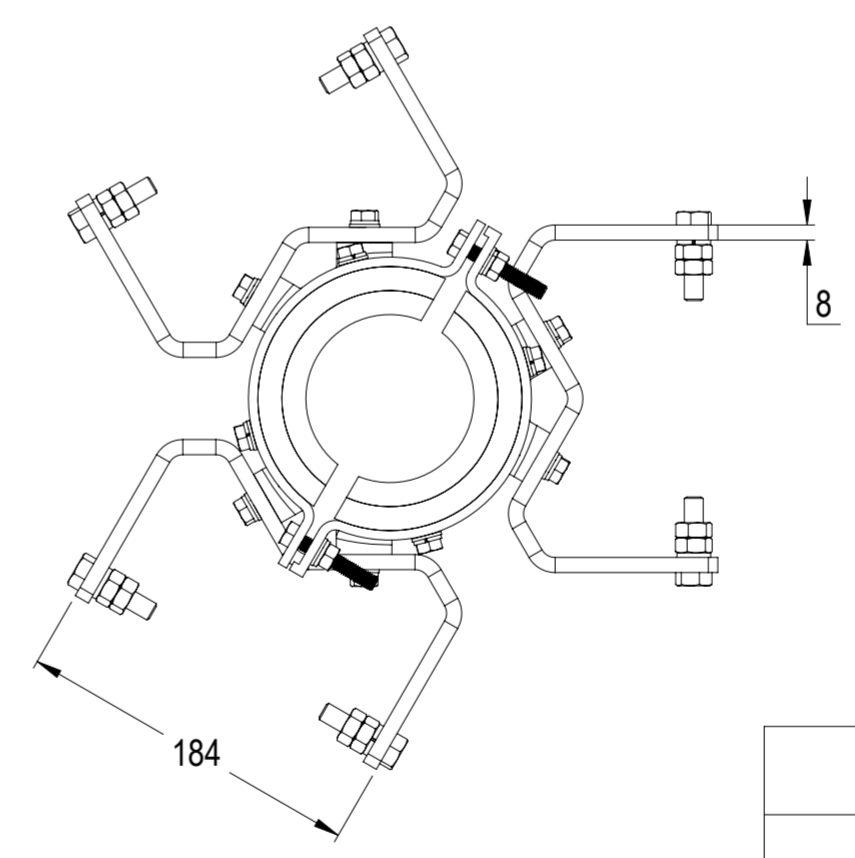
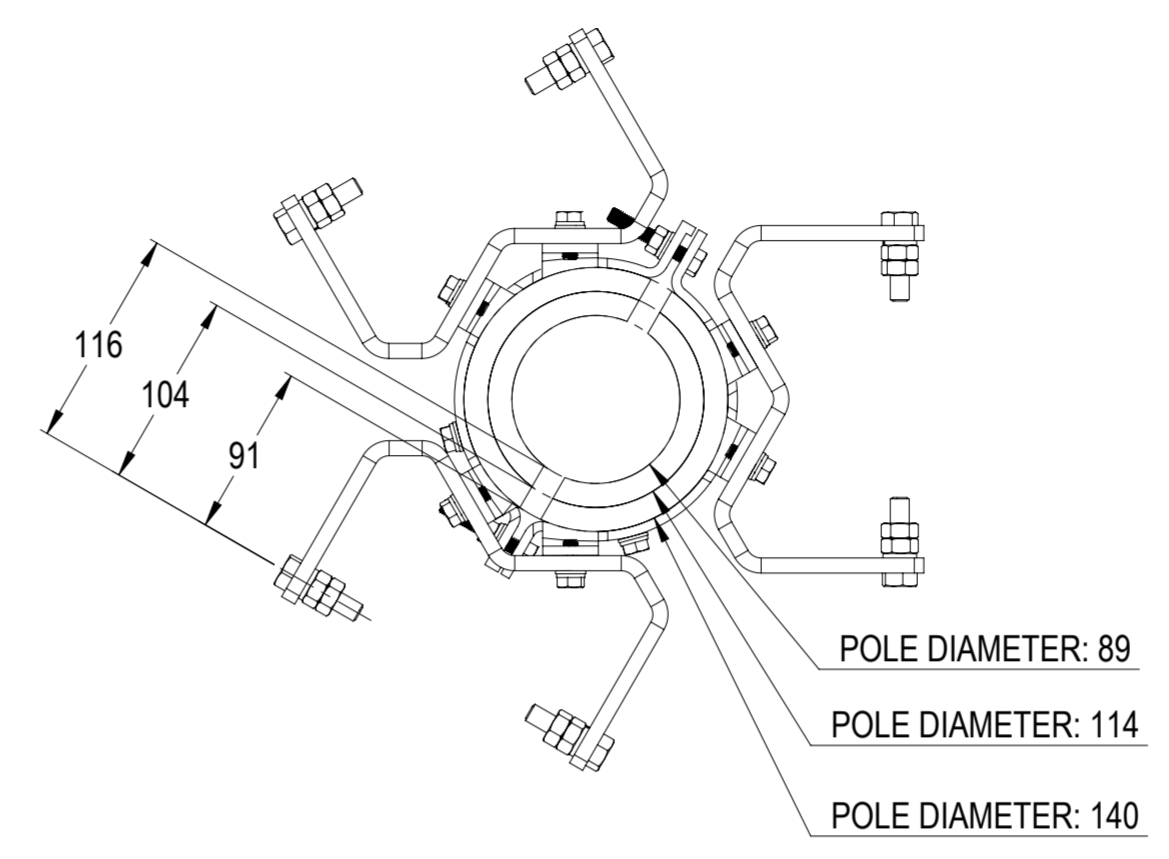
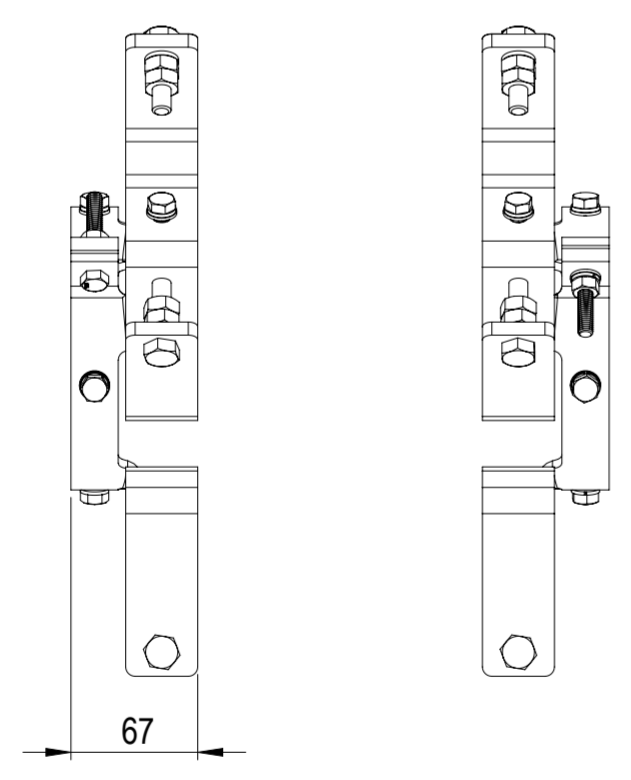
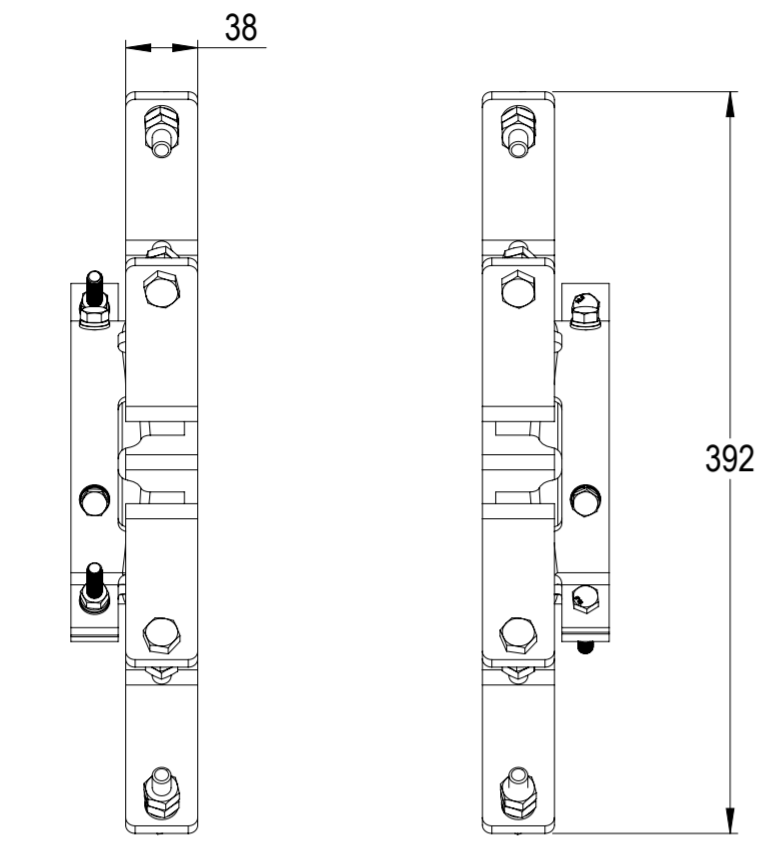

800PIPEKIT-XL

© 2019 CommScope, Inc.

COMMScope, INC. OF NORTH CAROLINA											
TOLERANCES						SAP MATERIAL MASTER					
0 PLACE X ±			2 PLACE .XX ±			1 PLACE .X ±			ANGLES ±		
FINISH						MATERIAL					
PRODUCT DRAWING											
<small>UNLESS OTHERWISE SPECIFIED DIMENSIONS ARE IN MILLIMETERS INTERPRET PER ISO STANDARDS HANDBOOK TECHNICAL DRAWINGS VOLUMES 1 & 2, THIRD EDITION (2002)</small>											
		NAME		DATE		TITLE					
CE		QW1012		11/04/2019		SCALE 1:4 DOCUMENT NO. 800PIPEKIT-XL-L					
RW		QW1012		11/04/2019							
RV		CC1072		11/04/2019							
AD		TZ1021		11/04/2019							
RE		XYHANG		11/04/2019							
ECN 8000037919-O											
SIZE		WORK AREA		23		MODEL			DRAWING		
A2				VERSION		STATUS		REVISION		DRAWING	
				00		RE		A		00	
HEIGHT		LENGTH		WIDTH		SHEET		1 OF 1			

DENSITY	g/mm ³
MASS	grams
VOLUME	mm ³
SURFACE AREA	mm ²