

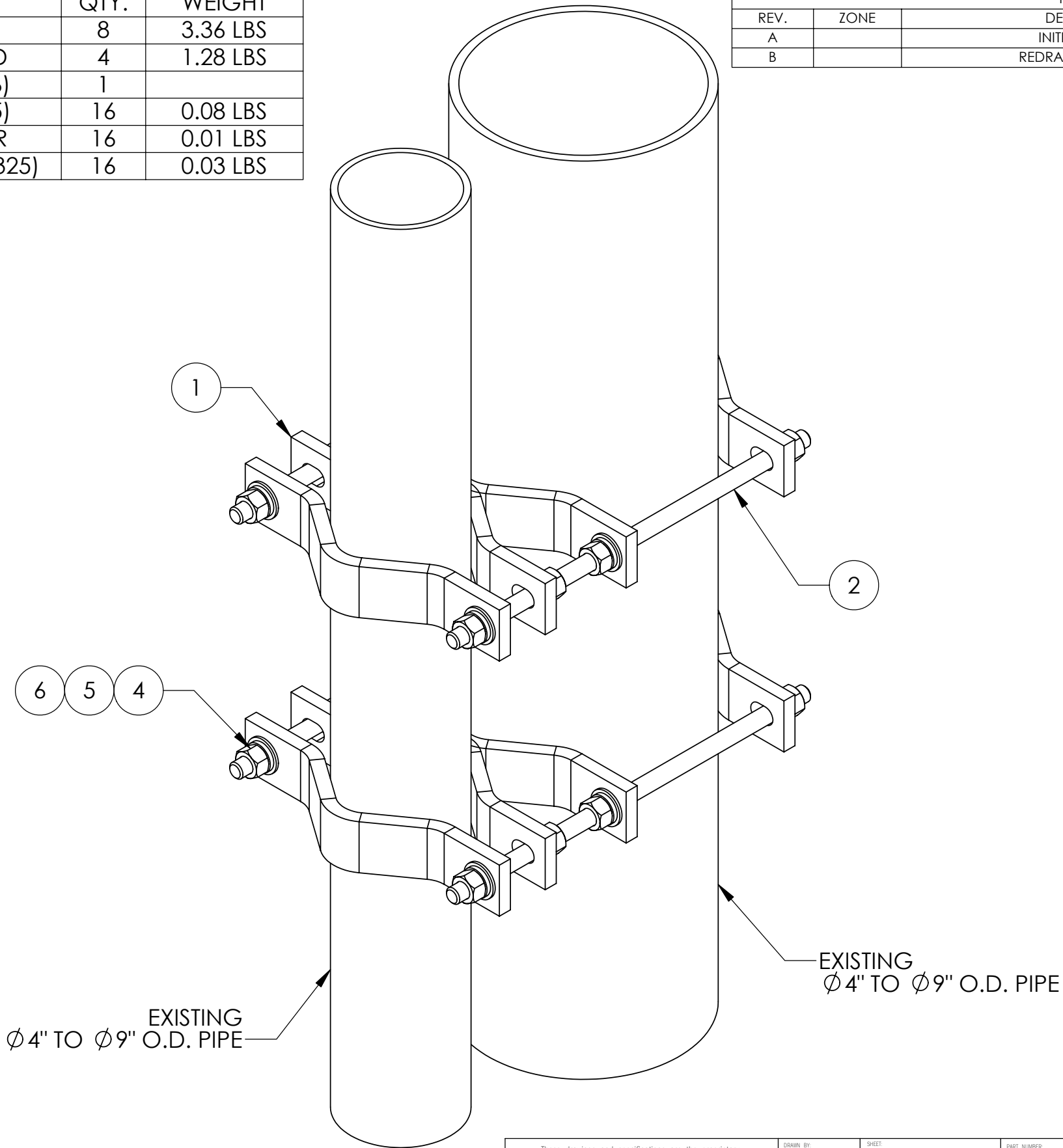

| ITEM | PART NO. | DESCRIPTION | QTY. | WEIGHT |
|------|-----------|------------------------------|------|----------|
| 1 | MC-P10 | MEDIUM CLAMP HALF | 8 | 3.36 LBS |
| 2 | MT-382-16 | 5/8" X 16" THREADED ROD | 4 | 1.28 LBS |
| 3 | HB5816 | HARDWARE KIT (ITEMS 4-6) | 1 | |
| 4 | GN05A | 5/8" GALV HEX NUT (A325) | 16 | 0.08 LBS |
| 5 | GWL-05 | 5/8" GALV LOCK WASHER | 16 | 0.01 LBS |
| 6 | GWF05A | 5/8" GALV FLAT WASHER (A325) | 16 | 0.03 LBS |

| REVISIONS | | | | |
|-----------|------|-------------------|-----|----------|
| REV. | ZONE | DESCRIPTION | BY | DATE |
| A | | INITIAL RELEASE | MLO | 08/05/99 |
| B | | REDRAWN & REVISED | DMW | 04/25/01 |



EXISTING
Ø 4" TO Ø 9" O.D. PIPE

EXISTING
Ø 4" TO Ø 9" O.D. PIPE

| | | | |
|---|-----------------------|--|--|
| These drawings and specifications are the proprietary property of ANDREW CORPORATION and may be used only for the specific purpose authorized in writing by Andrew Corporation. ALL DIMENSIONS ARE IN INCHES U.O.S. TOLERANCES UNLESS OTHERWISE SPECIFIED: .X = ± .06 ANGLES ± 2° .XX = ± .03 FRACTIONS ± 1/32 .XXX = ± .010 REMOVE BURRS AND BREAK EDGES .005 DO NOT SCALE THIS PRINT | DRAWN BY: ACG | SHEET: 1 of 1 | PART NUMBER: BC-40-16 |
| | CHECKED BY: TP | SCALE: NTS | DESCRIPTION: PIPE TO PIPE CLAMP |
| | DATE: 10/14/05 | MATERIAL: A36 | DRAWING TYPE: ASSEMBLY DRAWING |
| | REVISION: B | FINISH: GALV A123 WEIGHT: 24.33 LBS |  ORLAND PARK, IL. 60462 U.S.A. |