

| LOC |     | DIST                 |           | REVISIONS |      |  |  |
|-----|-----|----------------------|-----------|-----------|------|--|--|
| P   | LTR | DESCRIPTION          | DATE      | DWN       | APVD |  |  |
| G1  |     | REV: MCO-40026404MCO | 19NOV2015 | HG        | H    |  |  |
| H   |     | REV PER BNS_CD_BRAND | 16JAN2017 | GG        | DC   |  |  |

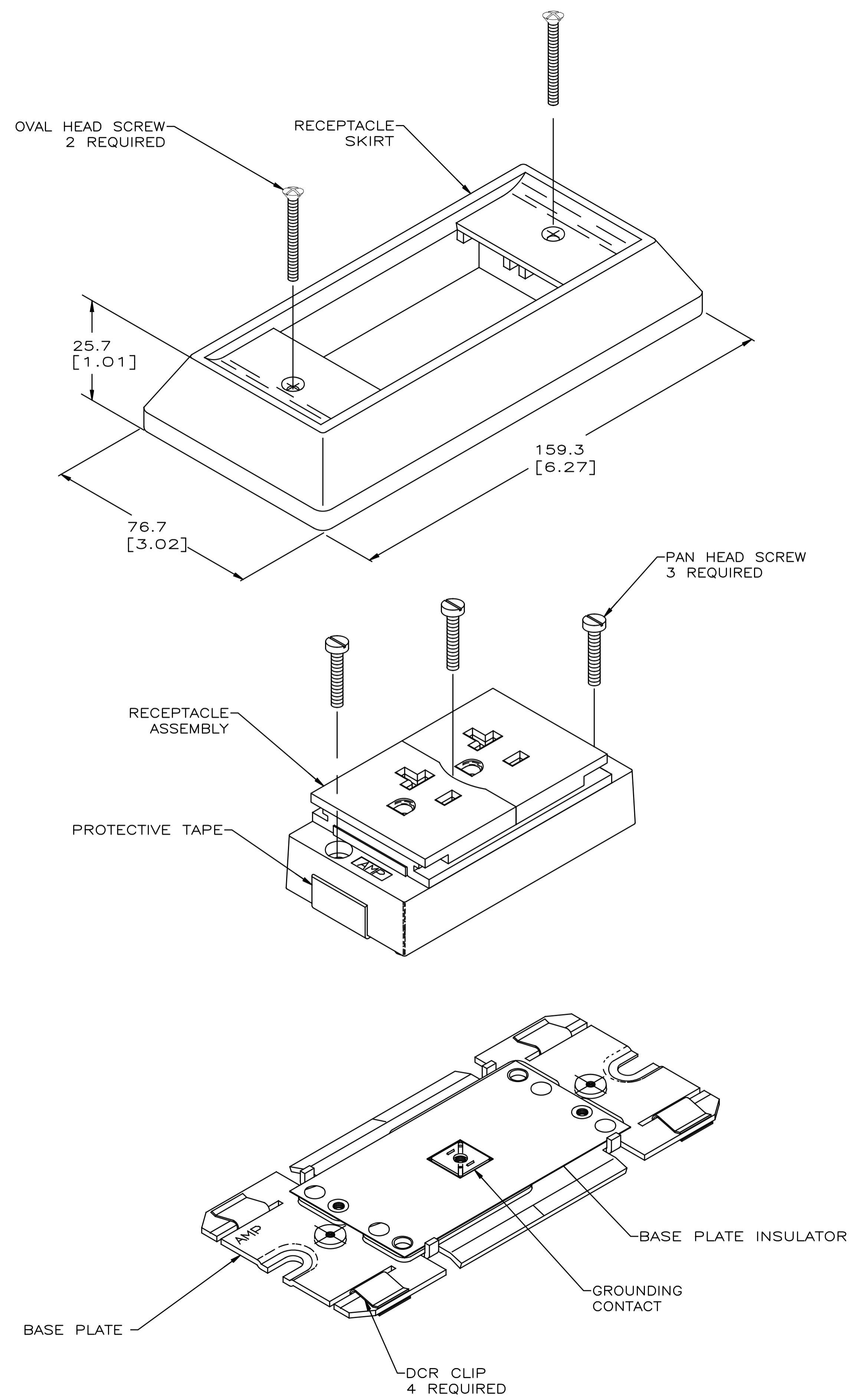

- ⚠ ALL DIMENSIONS SHOWN ARE MAXIMUM UNLESS OTHERWISE SPECIFIED.
- 2. HARDWARE SHIPPED NOT ASSEMBLED.
- ⚠ MATERIAL: SKIRT - ABS MOLDING COMPOUND. RECEPTACLE ASSEMBLY - SLIDING COVER, POLYCARBONATE MOLDING COMPOUND; BASE, PBT MOLDING COMPOUND. BASE PLATE - PREGALVANIZED STEEL. BASE PLATE INSULATOR - VULCANIZED FIBRE. HARDWARE - ZINC PLATED STEEL. DCR CLIP - STAINLESS STEEL. TERMINALS AND GROUNDING CONTACT - COPPER ALLOY.

|                  |          |
|------------------|----------|
| BLACK            | 553947-1 |
| RECEPTACLE COLOR | PART NO. |

**COMMSCOPE, INC.**

DIRECT CONNECTING RECEPTACLE,  
3 CONDUCTOR, DUPLEX, 15/20A

|  |     |                             |  |  |
|--|-----|-----------------------------|--|--|
| THIS DRAWING IS A CONTROLLED DOCUMENT. |     | DWN: G. GARRETT 18MAR97     |  |  |
| DIMENSIONS: mm [INCHES]                |     | CHK: G. GARRETT 18MAR97     |  |  |
| TOLERANCES UNLESS OTHERWISE SPECIFIED: |     | APVD: J. KILPATRICK 18MAR97 |  |  |
| 0 PLC                                  | ± - | NAME                        |  |  |
| 1 PLC                                  | ± - | PRODUCT SPEC                |  |  |
| 2 PLC                                  | ± - | APPLICATION SPEC            |  |  |
| 3 PLC                                  | ± - | 114-6008                    |  |  |
| 4 PLC                                  | ± - | SIZE                        |  |  |
| ANGLES                                 | ± - | CAGE CODE                   |  |  |
| FINISH                                 | ± - | DRAWING NO                  |  |  |
| MATERIAL                               | 3   | 114-6008                    |  |  |
|  | 3   | WEIGHT                      |  |  |
|  |     | —                           |  |  |
|  |     | CUSTOMER DRAWING            |  |  |
|  |     | SCALE 1:1                   |  |  |
|  |     | SHEET 1 OF 1                |  |  |
|  |     | REV H                       |  |  |