

4

3

2

1

THIS DRAWING IS UNPUBLISHED. RELEASED FOR PUBLICATION

© 2016 CommScope, INC. Confidential THESE DRAWINGS AND SPECIFICATIONS ARE THE PROPRIETARY PROPERTY OF COMMSCOPE, INC. AND MAY BE USED ONLY FOR THE SPECIFIC PURPOSE AUTHORIZED IN WRITING BY COMMSCOPE, INC.

LOC	DIST	REVISIONS				
		REV	DESCRIPTION	DATE	BY	APP'D
HM	00	F	REV: ECO-12-020494	26NOV2012	GG	MS
		G	REV PER BNS_CD_BRAND	16JAN2017	GG	DC

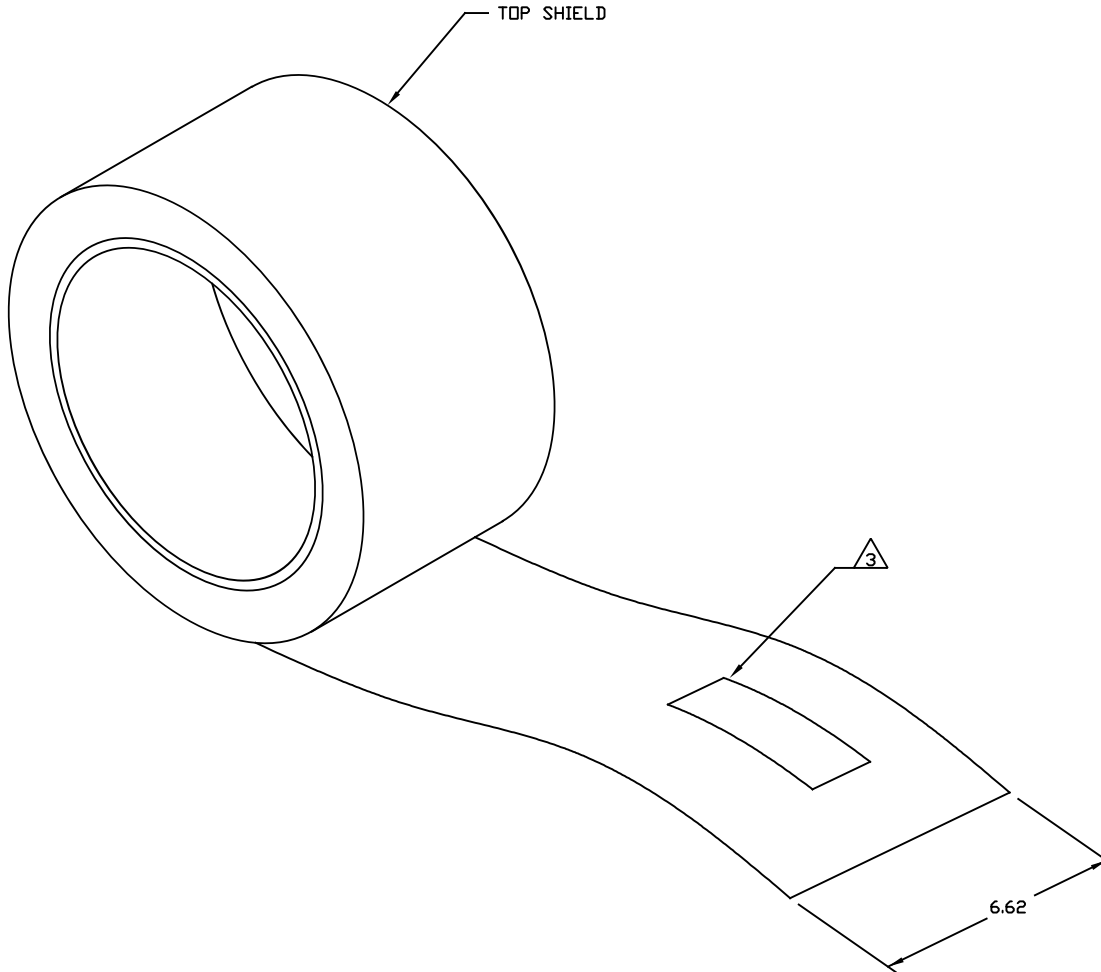

- ALL DIMENSIONS SHOWN ARE FOR REFERENCE ONLY UNLESS OTHERWISE SPECIFIED.
- MATERIAL: 304 STAINLESS STEEL STRIP, .010 THICK.
- SHIELD MARKED IN CENTER OF STRIP EVERY 2 FEET WITH THIS SIDE UP, TYCO ELECTRONICS PN 553536; 10/12 AWG @ ●. WARNING THIS CIRCUIT MUST BE DE-ENERGIZED BEFORE REMOVAL OF THIS METAL SHIELD. THIS SYSTEM MUST BE SERVICED BY AN AUTHORIZED ELECTRICIAN. AVERTISSEMENT-METTRE LE CIRCUIT HORS-TENSION AVANT D'ENLEVER L'ECRAN METALLIQUE. LE DÉPANNAGE DE CE SYSTÈME DOIT ÊTRE CONFIE À UN MATRE ÉLECTRICIEN AUTORISÉ.
- SEE INSTRUCTION SHEET 408-3150 FOR INSTALLATION INFORMATION.

30 FT	1-553536-7
100 FT	553536-4
50 FT	553536-3
250 FT	553536-1
LENGTH PER ROLL	PART NO.

THIS DRAWING IS A CONTROLLED DOCUMENT.		DWG: L HALL 08MAR2003	COMMSCOPE, INC.																													
DIMENSIONS: INCHES		CHK: L SIMPSON 08MAR03																														
TOLERANCES UNLESS OTHERWISE SPECIFIED:		APP'D: L SIMPSON 08MAR03	NAME: SHIELD, TOP, 3/5 CONDUCTOR CABLE, 10/12 AWG																													
<table border="1"> <tr><td>0</td><td>PLC</td><td>±</td><td>-</td></tr> <tr><td>1</td><td>PLC</td><td>±</td><td>-</td></tr> <tr><td>2</td><td>PLC</td><td>±</td><td>-</td></tr> <tr><td>3</td><td>PLC</td><td>±</td><td>-</td></tr> <tr><td>4</td><td>PLC</td><td>±</td><td>-</td></tr> <tr><td>5</td><td>PLC</td><td>±</td><td>-</td></tr> <tr><td>ANGLES</td><td></td><td>±</td><td>-</td></tr> </table>		0	PLC	±	-	1	PLC	±	-	2	PLC	±	-	3	PLC	±	-	4	PLC	±	-	5	PLC	±	-	ANGLES		±	-	PRODUCT SPEC: -	RESTRICTED TO: -	
0	PLC	±	-																													
1	PLC	±	-																													
2	PLC	±	-																													
3	PLC	±	-																													
4	PLC	±	-																													
5	PLC	±	-																													
ANGLES		±	-																													
MATERIAL: 2	FINISH: -	APPLIC. SPEC: -	SIZE: A2	CAGE CODE: -																												
MATERIAL: 2		WEIGHT: -	DRAWING NO: ©=553536	SCALE: NONE																												
CUSTOMER DRAWING		SHEET 1 of 1		REV G																												

553536