

# Installation Instructions



## Connectors

for 1/2" HELIAX® LDF4-75 Coaxial Cable

Andrew Institute offers installation training.

### Tools and Materials Required for Assembly

Damp cloth	Hacksaw, fine tooth blade
Knife	Scale, 6 in. (150 mm)
Flat file	Solvent: comothene, vythene or other non-flammable cleaning solvent
Garnet cloth	Spacing gauge, 1/16" (supplied)
Rosin flux	Wire brush, small
Soft solder	Wrenches: 13/16"
Soldering gun	

### Notice

The installation, maintenance or removal of antenna systems requires qualified, experienced personnel. Andrew installation instructions have been written for such personnel. Antenna systems should be inspected once a year by qualified personnel to verify proper installation, maintenance and condition of equipment.

Andrew disclaims any liability or responsibility for the results of improper or unsafe installation practices.

**1 Prepare Cable.** The end of the cable must be straight for at least 10 inches (254 mm). Remove the jacket to the approximate dimension shown. Use a knife. Deburr the sharp end of the cut outer conductor.

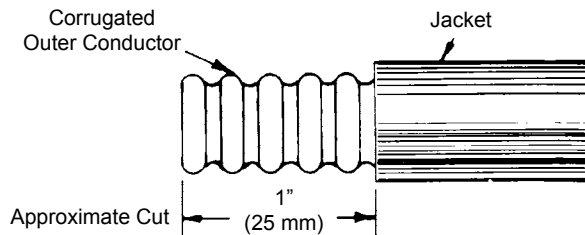

**2 Make Second Jacketing Cut.** Scribe a line on the ridge of the exposed corrugated outer conductor. The line must be at least 13/32 inch (10 mm) from the end of the cable. Remove the jacket to the dimension shown using a straight-edged piece of heavy paper wrapped around the cable to guide the cut. Cut the jacket with a sharp knife.

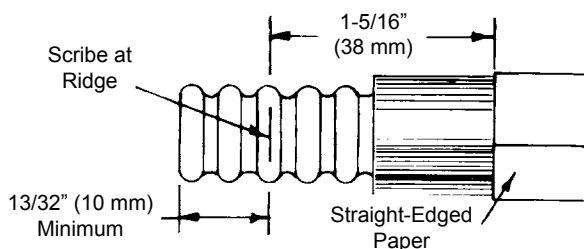

**3 Clean Conductor and Add O-ring.** Clean the outer conductor with solvent. Add the small O-ring to the second, fully-exposed conductor groove from the jacket. Apply a thin coating of silicone grease to the outer surface of the O-ring and to the O-ring lead chamfer in the clamping nut. **Note:** The clamping nut threads must be kept free of grease.

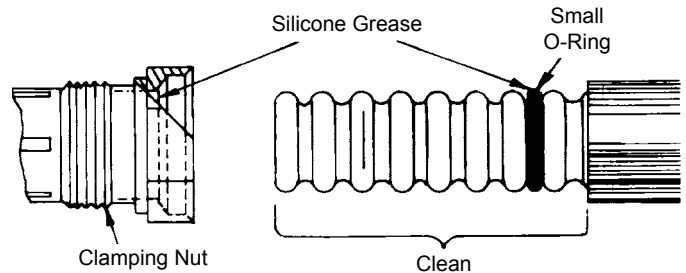

**4 Add Clamping Nut and Cut Cable.** Push the clamping nut onto the cable. Use a twisting motion to assure the spring contacts snap into the groove. Refer to the cutaway view in Step 7. Grip the clamping nut with one hand and align the edge with the line scribed in Step 2. Then carefully cut the outer conductor and foam dielectric material flush with the end of the clamping nut exposing the inner conductor. **Note:** Make shallow cuts to prevent damaging the inner conductor. Use a hacksaw with a fine-toothed blade or a model maker's saw.

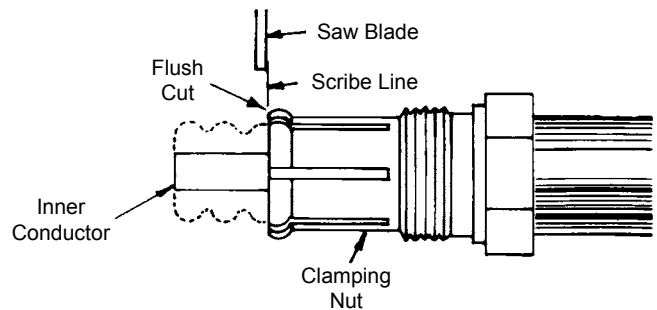

**5 Trim Inner Conductor.** Cut the inner conductor to the length shown. Use a file to deburr the cut end of the inner conductor.

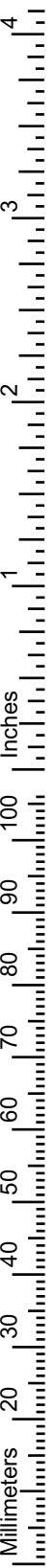
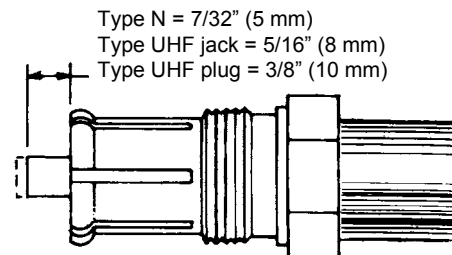

**6 Separate Foam from Outer Conductor.** Insert the tip of a knife to a depth of 1/16 inch (2 mm) between the foam dielectric and the outer conductor of the cable and separate them so that the outer conductor can be flared. Move the knife around the entire circumference of the outer conductor. Scrape away any foam clinging to the outer conductor. Remove any burrs from the inner edge of the outer conductor. Remove particles from the foam with a wire brush.

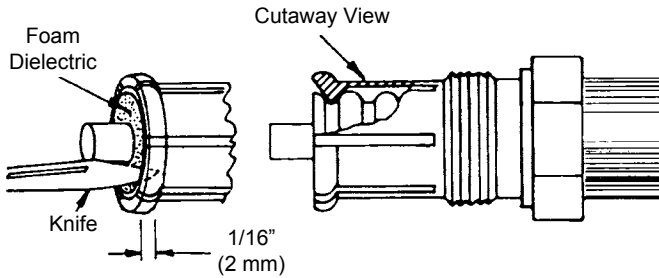

**7 Flare Outer Conductor.** Thread the connector outer body onto the clamping nut and tighten the connection with wrenches. Hold the clamping nut stationary and turn only the outer body to 12.2 ±2.2 lbf-ft (16 ±3 N·m). The flaring surface of the outer body will flatten the outer conductor against the clamping nut ring. Disassemble the connection and inspect the flare to ensure good metal-to-metal contact at final assembly.

**Internal Flaring Details of Connector Assembly**

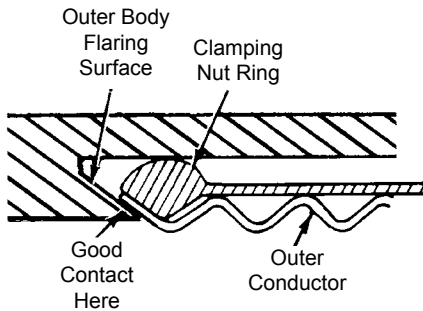

**8 Install Inner Connector.** Clean the inner conductor. Slip the inner connector onto the inner conductor. Use the spacing gauge as indicated. Solder the inner connector to the inner conductor while pressing the inner connector against the spacing gauge. Cool the soldered connection with a damp cloth and clean with garnet cloth. Make certain the inner connector is straight; i.e. square to the flared outer conductor. Place the large O-ring into the groove in the clamping nut and apply a thin coating of silicone grease to the outer surface of the O-ring. Keep the connector threads free of grease. Thread the connector outer body onto the clamping nut and tighten the connection with wrenches. Hold the clamping nut stationary and turn the outer body only to 12.2 ±2.2 lbf-ft (16 ±3 N·m).

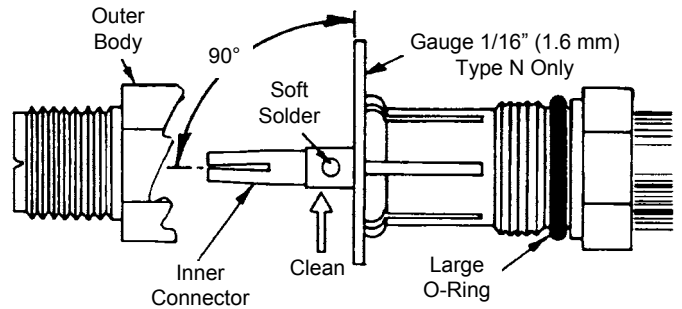

	表一 有毒有害物质或元素名称及含量标识格式					
	有毒有害物质或元素					
部件名称 (Part Name)	铅 (Pb)	汞 (Hg)	镉 (Cd)	六价铬 (Cr6+)	多溴联苯 (PBB)	多溴二苯醚 (PBDE)
连接器 (Connector)	X	O	O	O	O	O

O: 表示有毒有害物质在该部件所有的均质材料中的含量均在SJ/T 11363-2006规定的限量要求以下。  
 X: 表示该有毒有害物质至少在该部件的某一均质材料中的含量超出SJ/T 11363-2006规定的限量要求。

**Andrew Corporation**  
 3 Westbrook Corporate Center, Suite 900, Westchester, Illinois U.S.A. 60154  
 +1 (708) 349-3300 Fax (U.S.A.): 1-800-349-5444  
 www.andrew.com

**Customer Service 24 hours**  
 U.S.A., Canada, Mexico: 1-800-255-1479  
 U.K.: 0800 250055  
 Other Europe: +44 592 782 612

Notice: Andrew disclaims any liability or responsibility for the results of improper or unsafe installation, inspection, maintenance, or removal practices.  
 Aviso: Andrews no acepta ninguna obligación ni responsabilidad como resultado de prácticas incorrectas o peligrosas de instalación, inspección, mantenimiento o retiro.  
 Avis : Andrew décline toute responsabilité pour les conséquences de procédures d'installation, d'inspection, d'entretien ou de retrait incorrectes ou dangereuses.  
 Hinweis: Andrew lehnt jede Haftung oder Verantwortung für Schäden ab, die aufgrund unsachgemäßer Installation, Überprüfung, Wartung oder Demontage auftreten.  
 Atenção: A Andrew abdica do direito de toda responsabilidade pelos resultados de práticas inadequadas e sem segurança de instalação, inspeção, manutenção ou remoção.  
 Avvertenza: Andrew declina eventuali responsabilità derivanti dall'esecuzione di procedure di installazione, ispezione, manutenzione e smontaggio improprie o poco sicure.  
 注意：Andrew 公司申明對於不恰當或不安全的安裝、檢驗、維修或拆卸操作所導致的後果不負任何義務和責任