

E11F13P47-V

Diplexer, 700/900 MHz, RJ40, dc block on all ports with hybrid connectors 4.3-10 input and 7/16 output

- Industry leading PIM performance
- dc/AISG blocking on all ports
- Single configuration
- Hybrid connectors 4.3-10 input and 7/16 output

Product Classification

Product Type Diplexer

General Specifications

Product Family CBC79X

Color Gray

Common Port Label PORT 3

Modularity 2-Twin

Mounting Pole | Wall

Mounting Pipe Hardware Band clamps (2)

RF Connector Interface 4.3-10 Female | 7-16 DIN Female

RF Connector Interface Body Style Long neck

Dimensions

Height 307 mm | 12.087 in

Width 170 mm | 6.693 in

Depth 101 mm | 3.976 in

RF Connector Length 25 mm | 0.984 in

Ground Screw Diameter 5 mm | 0.197 in

Mounting Pipe Diameter Range 42.6–122 mm

Outline Drawing

E11F13P47-V

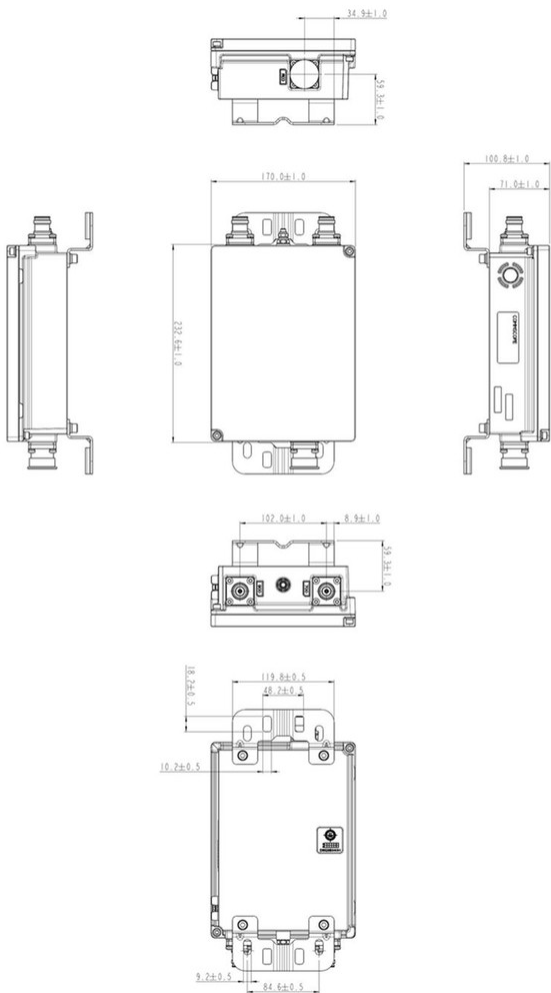

Electrical Specifications

Insertion Loss Ripple, maximum	0.2 dB
Electrical Safety Standard	EN 60950
Electromagnetic Compatibility/Interference (EMC/EMI)	EN 55022 ETSI 301 489-1 V1.8.1
Impedance	50 ohm
License Band, Band Pass	APT 700 CEL 900 EDD 800 LMR 750

Electrical Specifications, dc Power/Alarm

dc/AISG Pass-through Method	No dc/AISG pass-through
dc/AISG Pass-through, combiner	dc/AISG blocking on all ports
dc/AISG Pass-through, demultiplexer	dc/AISG blocking on all ports
Lightning Surge Current	10 kA

E11F13P47-V

Lightning Surge Current Waveform

8/20 waveform

Electrical Specifications

Sub-module	1 2	1 2
Branch	1	2
Port Designation	698-803	880-960
License Band	APT 700, Band Pass	CEL 900, Band Pass

Electrical Specifications, Band Pass

Frequency Range, MHz	698-803	880-960
Insertion Loss, maximum, dB	0.5	0.5
Insertion Loss, typical, dB	0.25	0.25
Return Loss, minimum, dB	18	18
Return Loss, typical, dB	20	20
Isolation, minimum, dB	50	50
Isolation, typical, dB	55	55
Input Power, RMS, maximum, W	200	200
Input Power, PEP, maximum, W	2000	2000
3rd Order PIM, typical, dBc	-158	-158
3rd Order PIM Test Method	Two +43 dBm carriers	Two +43 dBm carriers

Block Diagram

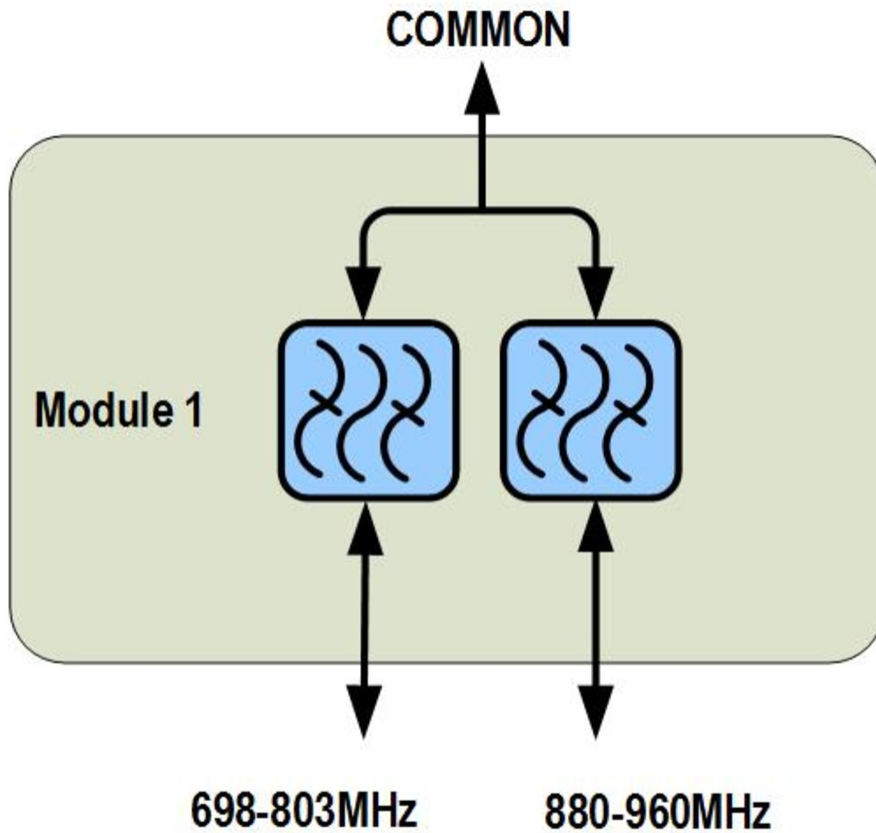

DC/AISG blocking on all ports

Material Specifications

Finish

Painted

Mechanical Specifications

Mechanical Shock Test Method

IEC 60068-2-27

Wind Speed, maximum

200 km/h | 124.274 mph

Environmental Specifications

Operating Temperature

-30 °C to +70 °C (-22 °F to +158 °F)

Corrosion Test Method

IEC 60068-2-11, 30 days

Environmental Test Method

ETSI EN 300 019-1-4

Ingress Protection Test Method

IEC 60529:2001, IP67

E11F13P47-V

Mean Time Between Failures, minimum	1000000 h
Thermal Shock Test Method	IEC 60068-2-14
UV Resistance Test Method	IEC 60068-2-5
Vibration Test Method	IEC 60068-2-6

Packaging and Weights

Included	Mounting hardware
Volume	2.8 L
Weight, net	4.1 kg 9.039 lb

Regulatory Compliance/Certifications

Agency	Classification
ISO 9001:2015	Designed, manufactured and/or distributed under this quality management system

