

- 1.0 GENERAL NOTES
  - 1.1 ALL METRIC DIMENSIONS ARE IN BRACKETS [X.X]
  - 1.2 FEATURES CRITICAL TO QUALITY ARE INDICATED IN ROUNDED BOX (XX)
  - 1.3 3D DIGITAL FILES ARE FOR REFERENCE. IN CASE OF CONFLICT FOLLOW PDF DRAWING
  - 1.4 WELD AREAS NOTED ARE CRITICAL TO QUALITY
- 2.0 DESIGN NOTES
- 3.0 MANUFACTURING/SPECIAL REQUIREMENTS
  - 3.1 BREAK SHARP EDGES AND DEBURR PART FOR SAFE HANDLING
  - 3.2 WELDING:
    - 3.2.A ALL WELDING SHALL CONFORM TO AWS D1.1, STEEL STRUCTURAL WELDING CODE
    - 3.2.B WELDING WORKMANSHIP SHALL BE PER AWS D1.1, TABLE 8.1 (VISUAL INSPECTION)
    - 3.2.C ALL WELDING SHALL BE PERFORMED BY CERTIFIED WELDERS
    - 3.2.D ALL WELD SLAG, SPATTER AND SHARP SHALL BE REMOVED PRIOR TO FINISH
    - 3.2.E WELDER ID TAG SHALL BE LOCATED APPROXIMATELY WHERE SHOWN FOR MANUFACTURER & WELDER TRACEABILITY. TAG SHALL HAVE MANUFACTURE ID (XXX) FOR VENDOR SUPPLIED AND WELDER ID (XXX) FOR COMMSCOPE/VENDOR WELDER. TAG CAN BE UP TO 1/8" THICK & UP TO 2" SQUARE WITH STAMPED/ENGRAVED TEXT NO LESS THAN 1/4" IN HEIGHT
  - 3.3 GALVANIZE PER ASTM A123
  - 3.4 MARK WITH PART NUMBER, REVISION, AND VENDOR ID WITH ETCH, STAMP OR LABEL. CHARACTERS TO BE 0.12" TO 0.24" HIGH AND LEGIBLE TO THE UNAIDED EYE.
- 4.0 TEST
- 5.0 PACKAGING
  - 5.1 PACKAGING SHALL MEET COMMSCOPE REQUIREMENTS PER DOCUMENT IS-PL-3005

REVISIONS			
REV.	DESCRIPTION	DATE	APPROVED
A	INITIAL RELEASE	JL1183 18OCT23	XK1001 40179678CMO

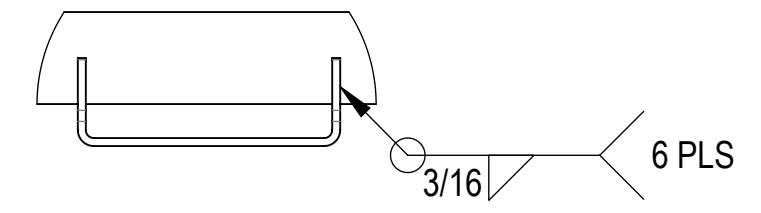

DETAIL B  
SCALE 1 : 6

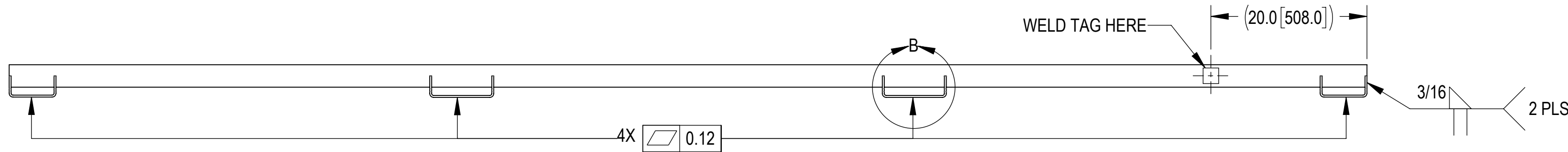
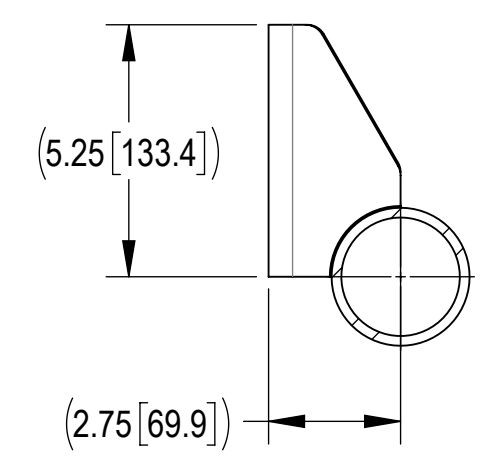
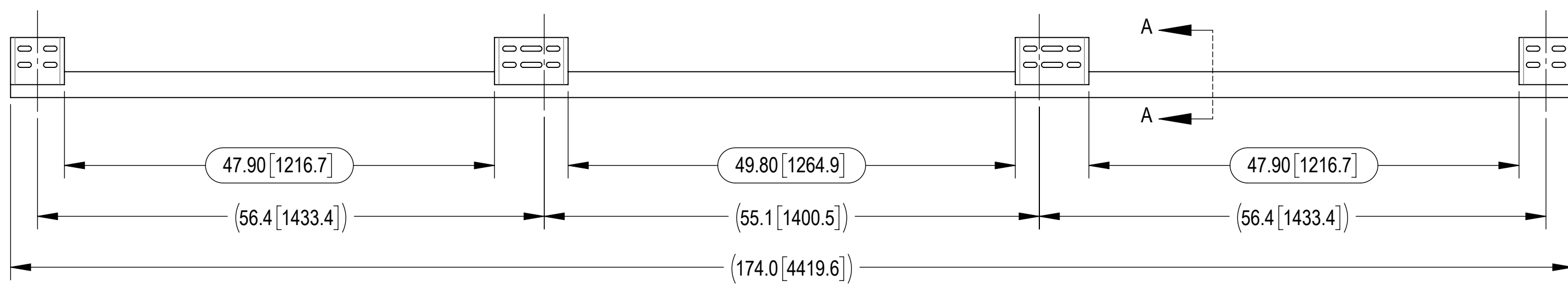

SECTION A-A  
SCALE 1 : 4

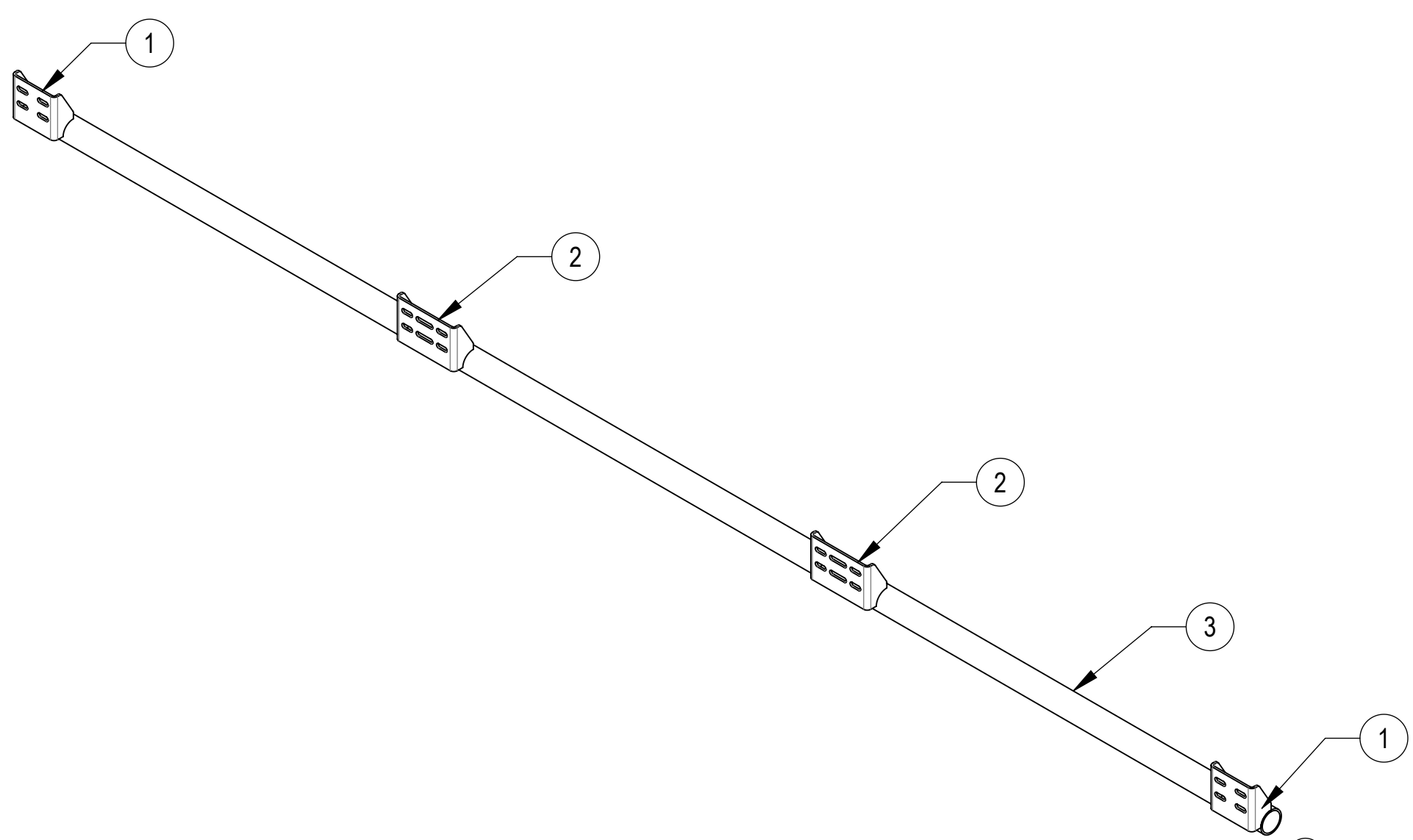

MID	FINISH
SFG-FP-14.5-4-56	GALV A123
SFG-FP-14.5-4-56-B	N/A

**COMMSCOPE, INC. OF NORTH CAROLINA**

TOLERANCES		SAP MATERIAL MASTER	
1 PLACE .X[X] ± 0.2[6.3]	3 PLACE .XXX[X] ± 0.060[1.5]	<b>SEE TABLE</b>	
2 PLACE .XX[X] ± 0.12[3.0]	ANGLES ± 2°		
FINISH SEE TABLE		MATERIAL	
<b>FACE-PIPE, 2.88" X 14.5', 4-POS, 56"</b>			
UNLESS OTHERWISE SPECIFIED DIMENSIONS ARE IN INCHES INTERPRET PER ANSI Y 14.5M-1994		SCALE <b>1:12</b>	DOCUMENT NO. <b>SFG-FP-14.5-4-56</b>
SIZE <b>C</b>		Auth Group INSL	MODEL VERSION STATUS REVISION 00 RE A
DRAWING VERSION STATUS REVISION 00 RE A		SHEET 1 OF 1	

DENSITY	98.16	lbs/in³
MASS	98.16	lbs
VOLUME	345.23	in³
SURFACE AREA	3364.49	in²
HEIGHT	6.69"	
LENGTH	174.0"	
WIDTH	4.19"	